



ASSEMBLY INSTRUCTION

Model: 1505F MADISON FULL BED.

PART LISTS			
NO.	Description	Sketch	Q'ty
A	HEADBOARD		1PC
B	FOOTBOARD		1PC
C	SIDE RAIL		2PCS
D	FOOTBOARD LEG		2PCS
E	SLAT		5PCS
F	SUPPORT LEG		5PCS

HARDWARE LISTS				
NO.	Description	Sketch	Size	Q'ty
1	BOLT		Ø5/16 * 1"	8PCS
2	FLAT WASHER		Ø5/16 * 20*2	8PCS
3	ALLEN KEY		Ø 4 * 100	1PC
4	WOOD SCREW		Ø 4 * 30	10PCS
5	BOLT		30*1/4	5PCS

STEP 1

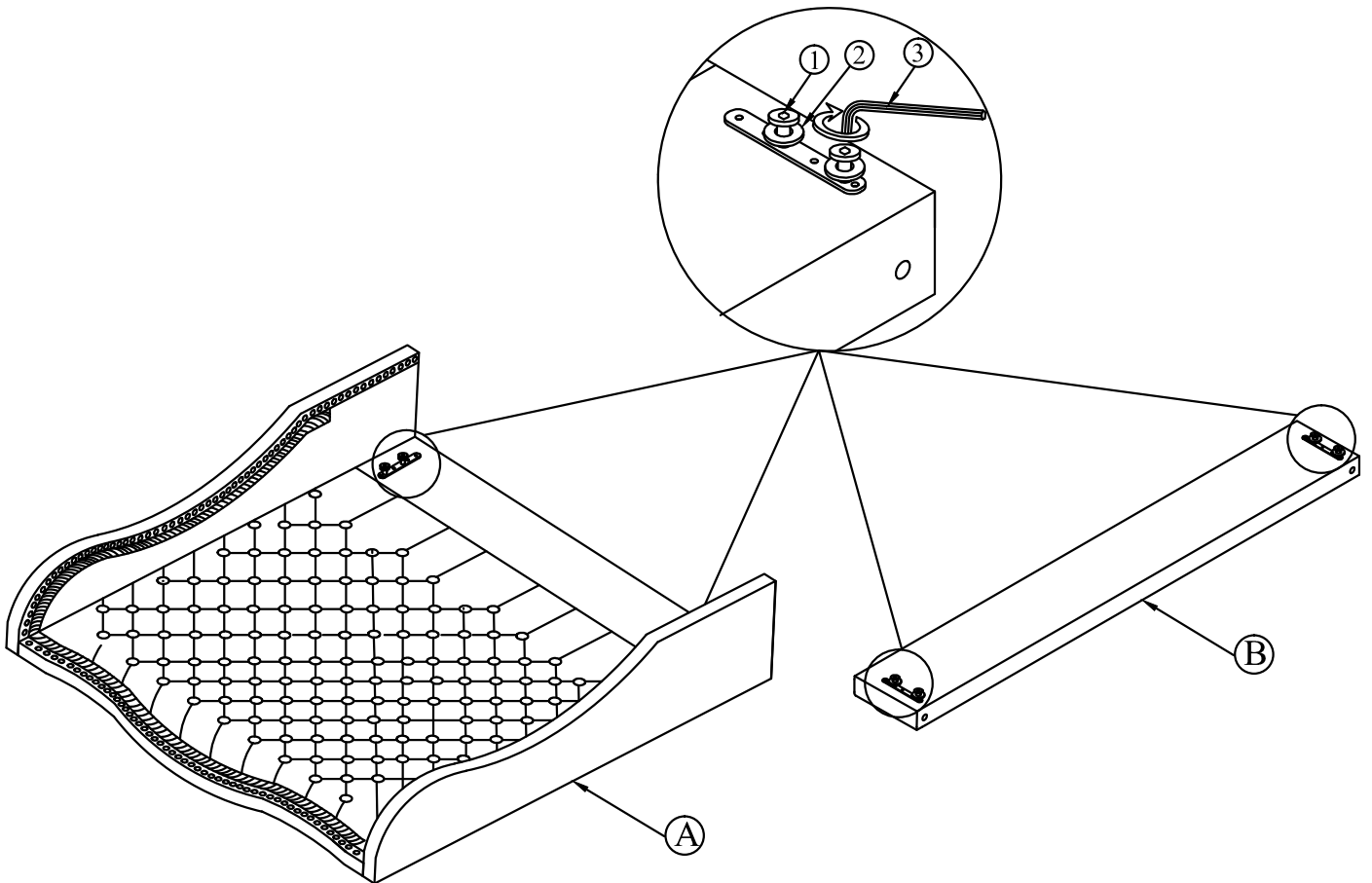

STEP 2

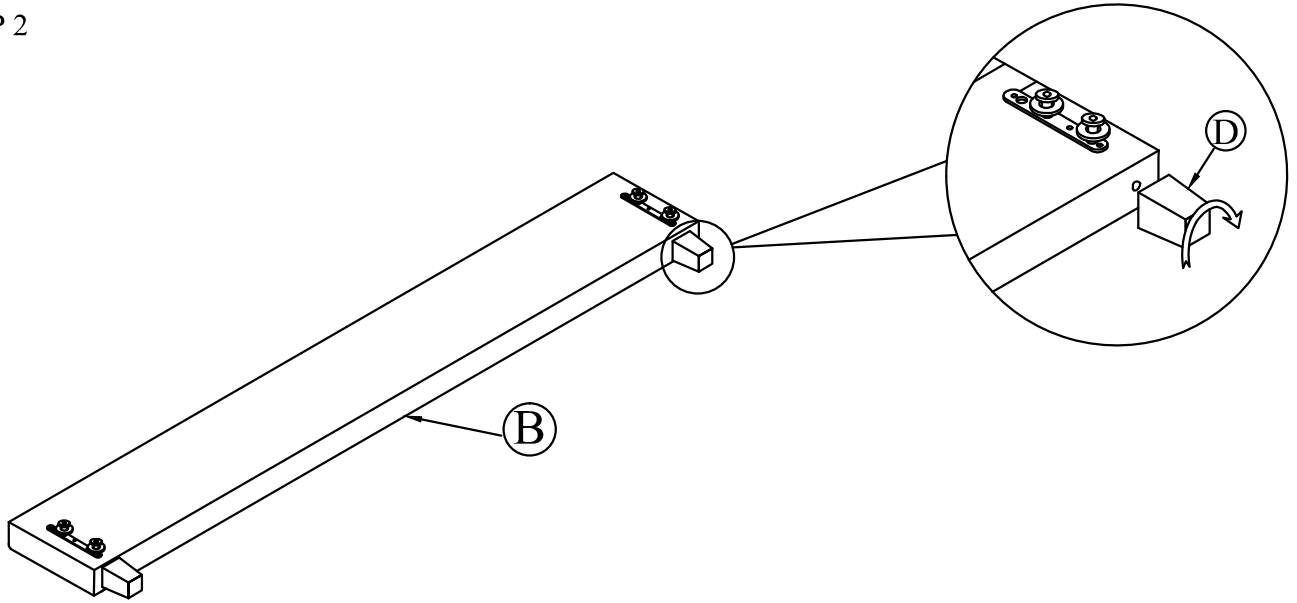

STEP 3

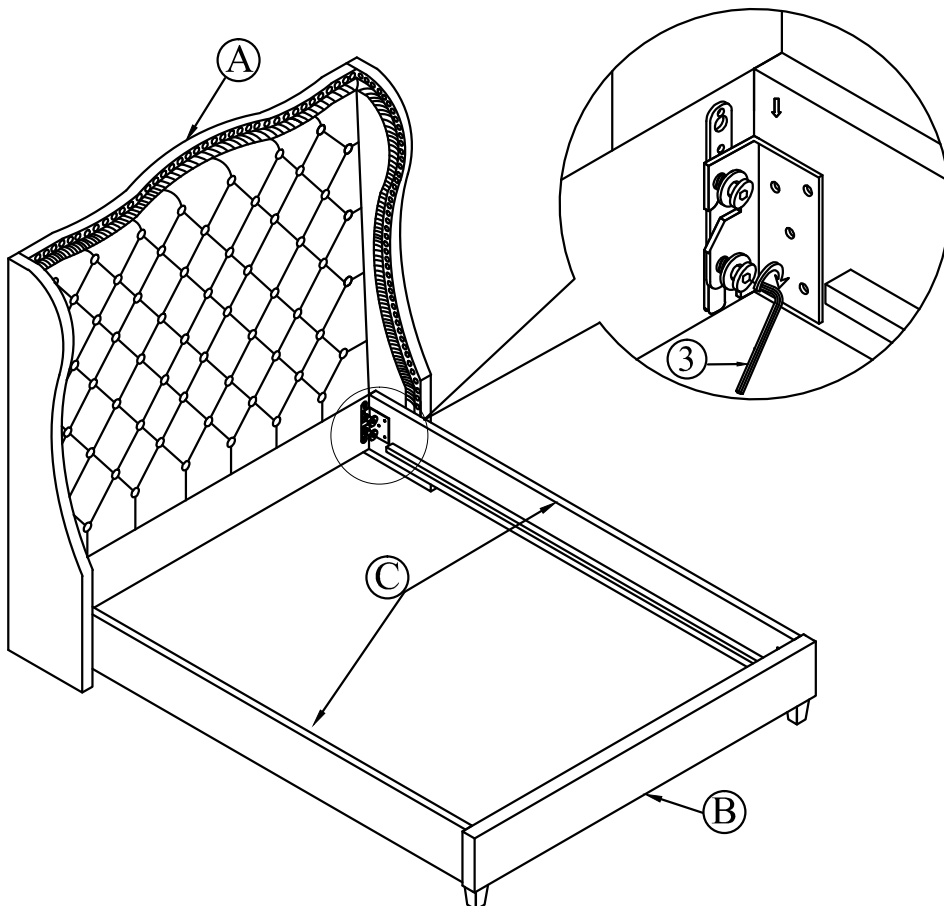



ASSEMBLY INSTRUCTION
Model: 1505F MADISON FULL BED.

STEP 4

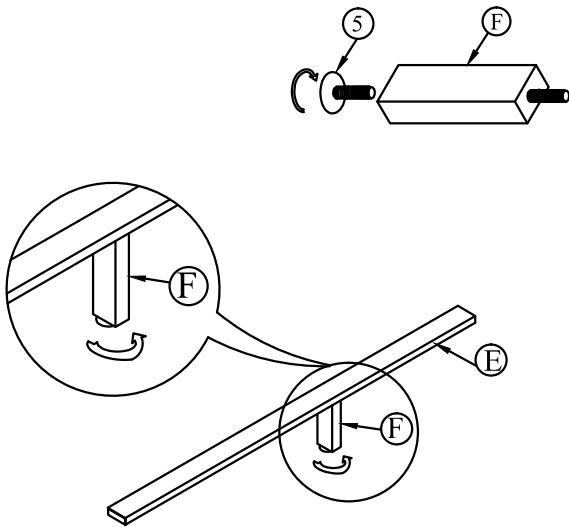

STEP 5

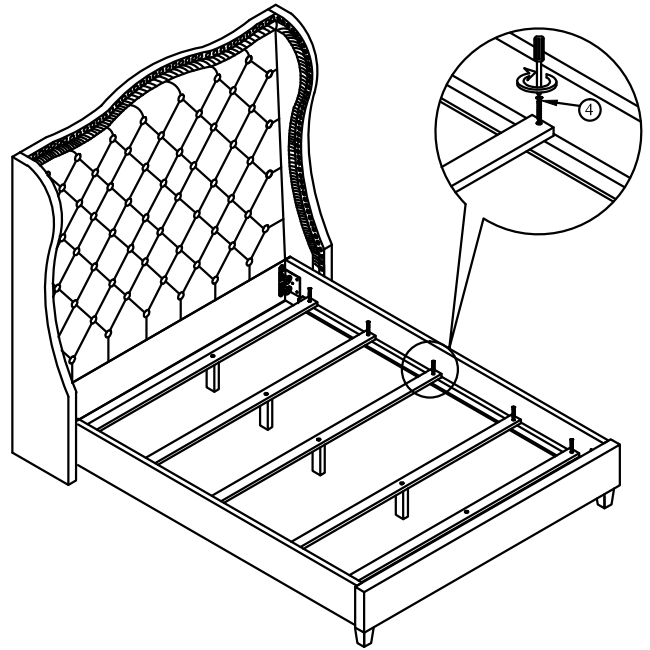

STEP 6

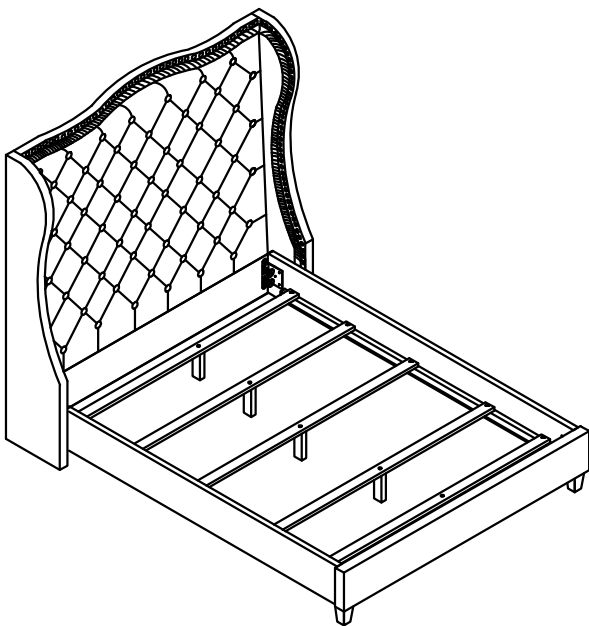

STEP 7

COMPLETED !

