

# ASSEMBLY INSTRUCTIONS

## V625 Full Bed Venice



Thank you for purchasing this quality product. Be sure to check all packing material carefully for small parts which may have come loose inside the carton during shipment. Separate, identify and count all parts and hardware.

Compare with the parts list to be sure all parts are present.

**“DO NOT TIGHTEN SCREWS UNTIL COMPLETELY ASSEMBLED”**

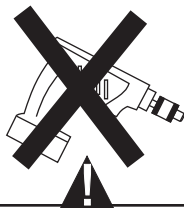

\* Use of power tool to assemble this product will invalidate any claim and damage this product making unsafe !!!  
\* Please assemble on a clean soft surface to avoid damage.

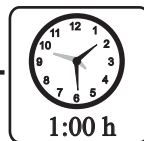

### Tools Required

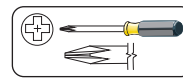

(Not included)

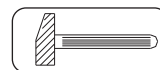

(Hammer)

### IMPORTANT:

**PLEASE READ INSTRUCTION BEFORE STARTING THE ASSEMBLY**

Part List: - V625 FULL BED VENICE

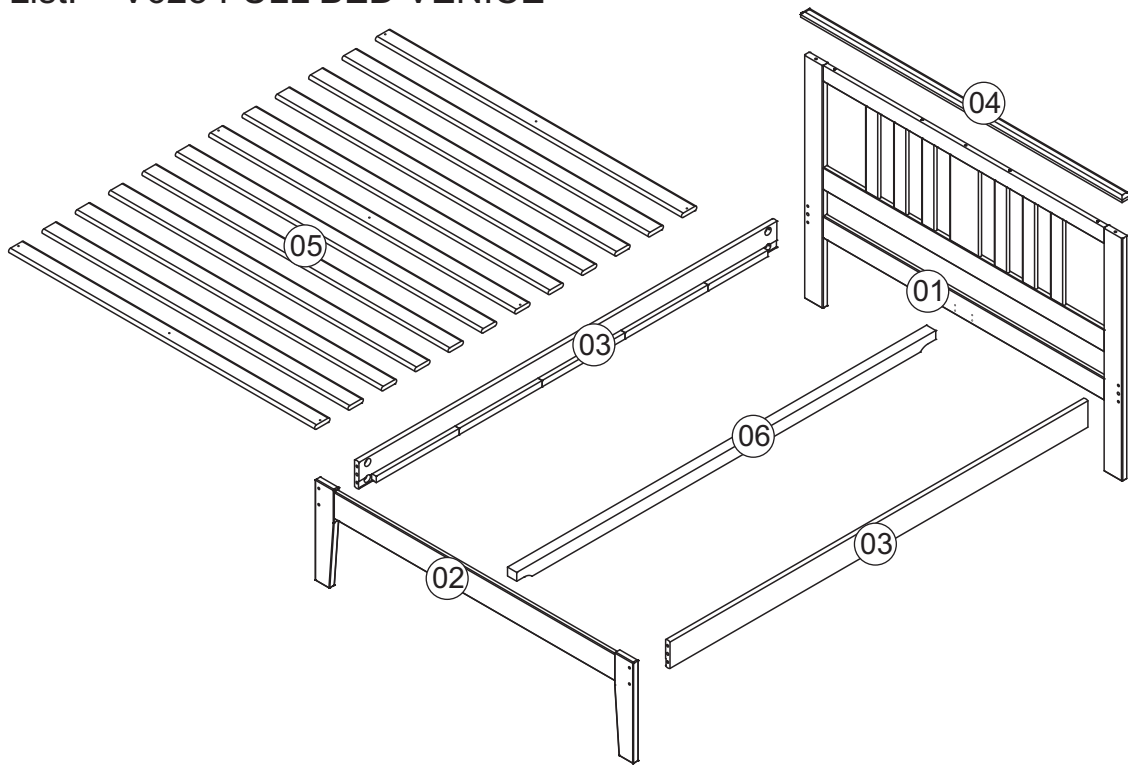

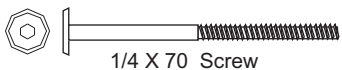

Identifying the Hardware/part list- Identify the hardware using the illustrations below.

**A**  Qty **08**  
1/4 X 70 Screw

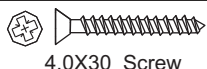
**B**  Qty **08**  
1/4" Half Moon

**C**  Qty **13**  
4,0X30 Screw

**D**  Qty **01**  
0,4mm/ Hex Screwdriver

**E**  Qty **04**  
10X40 Wood Dowel

**F**  Qty **03**  
8,0X35 Wood Dowel

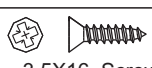
**G**  Qty **12**  
3,5X16 Screw

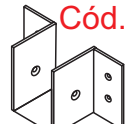
**H**  Qty **02**  
Cód.: 4072

01

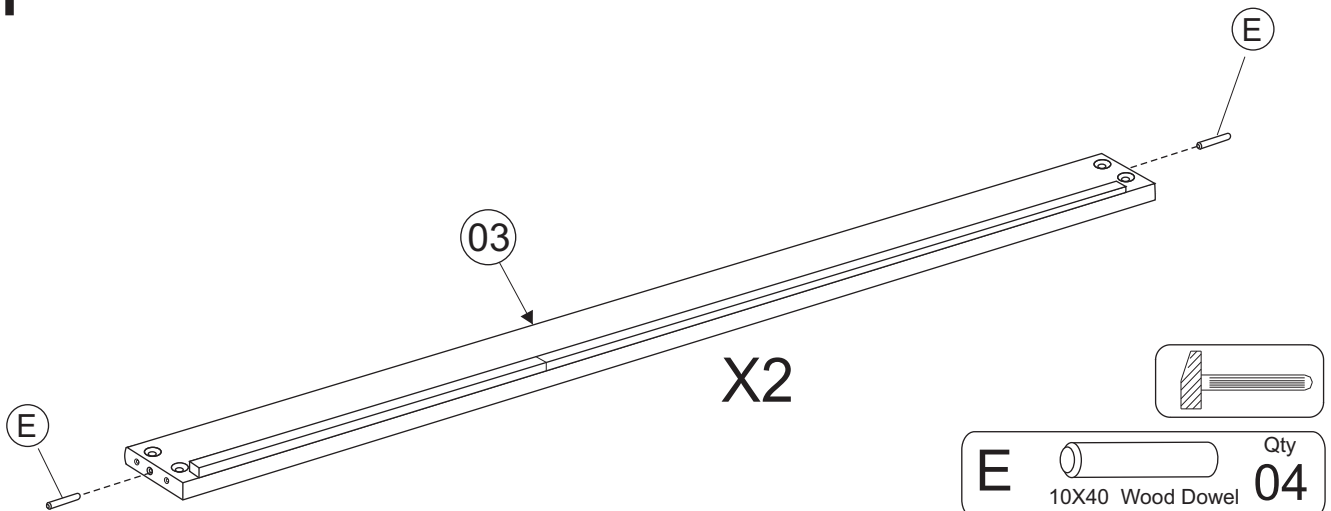

# 02

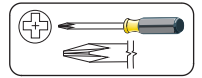
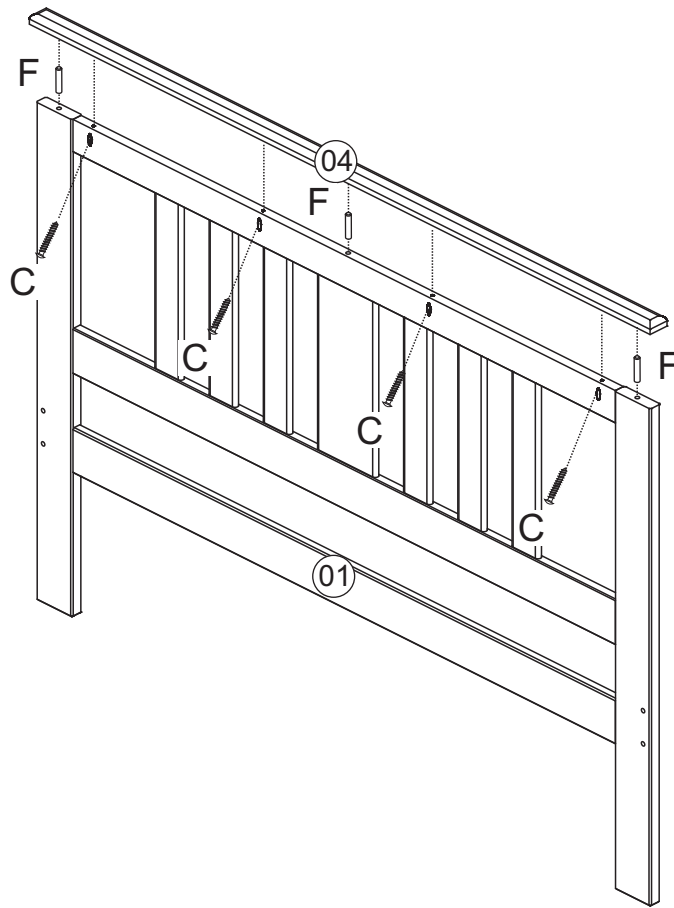

**C**  4,0X30 Screw Qty **04**

**F**  8,0X35 Wood Dowel Qty **03**

# 03

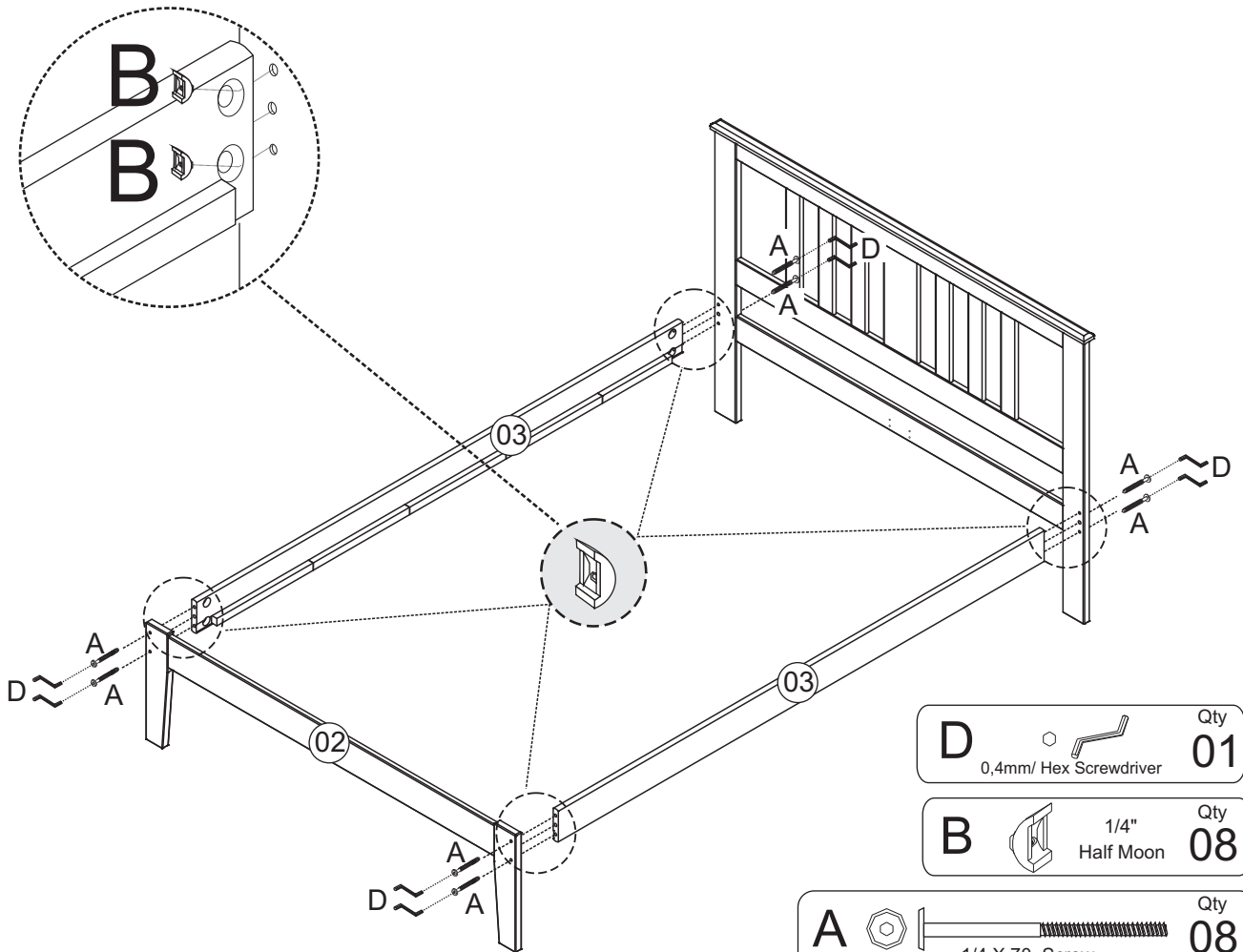

**D**  0,4mm/ Hex Screwdriver Qty **01**

**B**  1/4" Half Moon Qty **08**

**A**  1/4 X 70 Screw Qty **08**

# 04

When fixing the Support (H) carefully line up the screw holes with those pre-drilled marks on the Headboard and Footboard, this will ensure the best assembly.

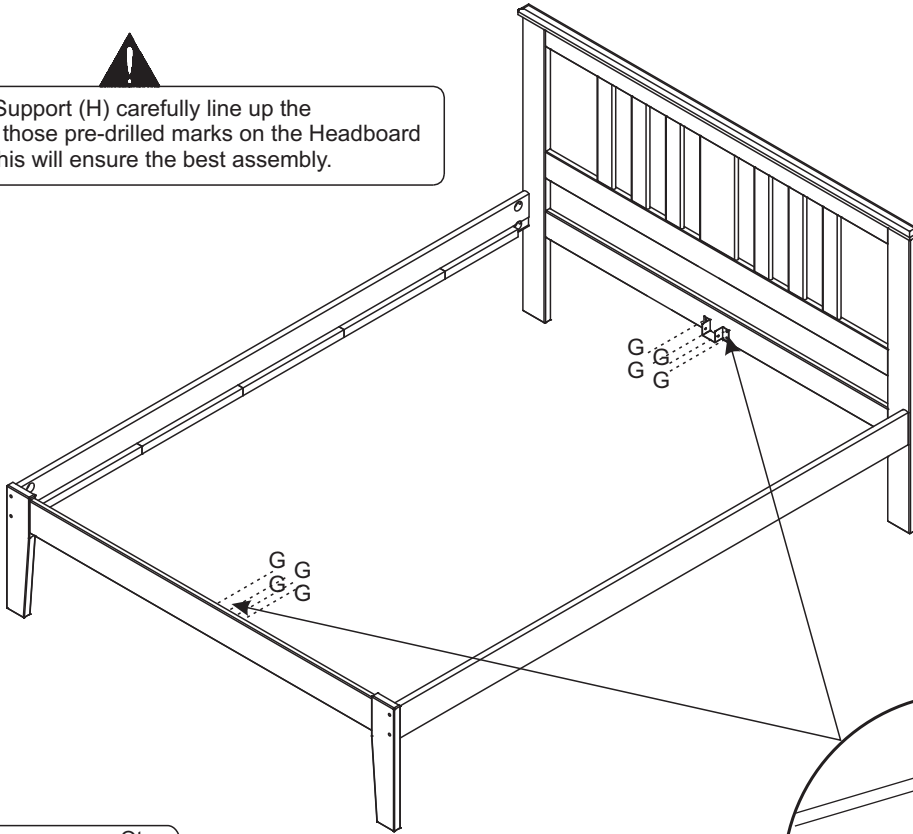

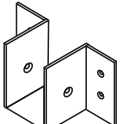

**G**  3,5X16 Screw Qty **08**

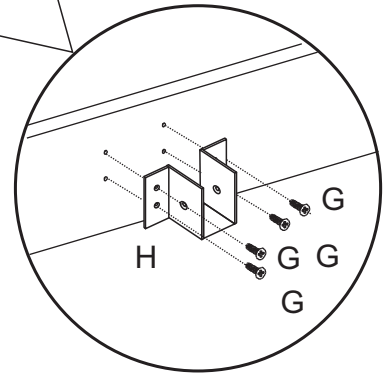
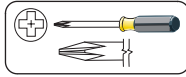
**H**  Qty **02**

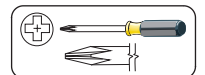
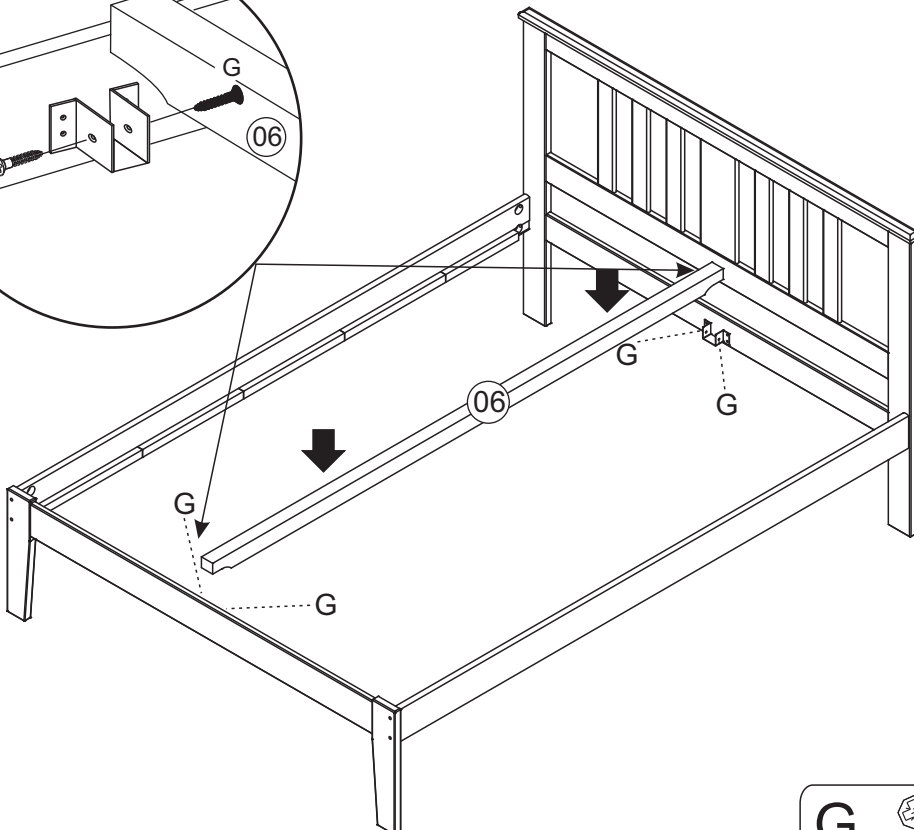
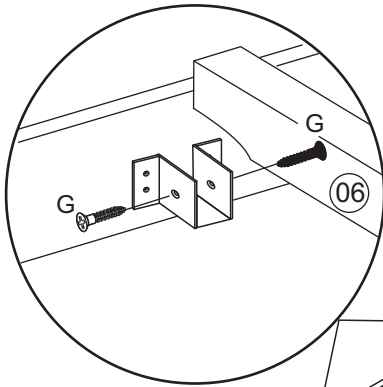

# 05



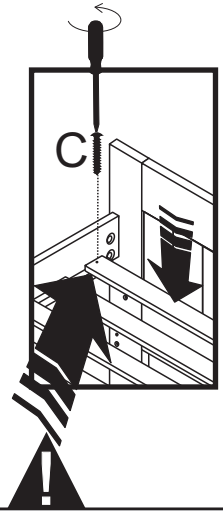

**G**  3,5X16 Screw Qty **04**

# 06

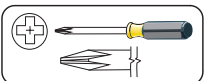
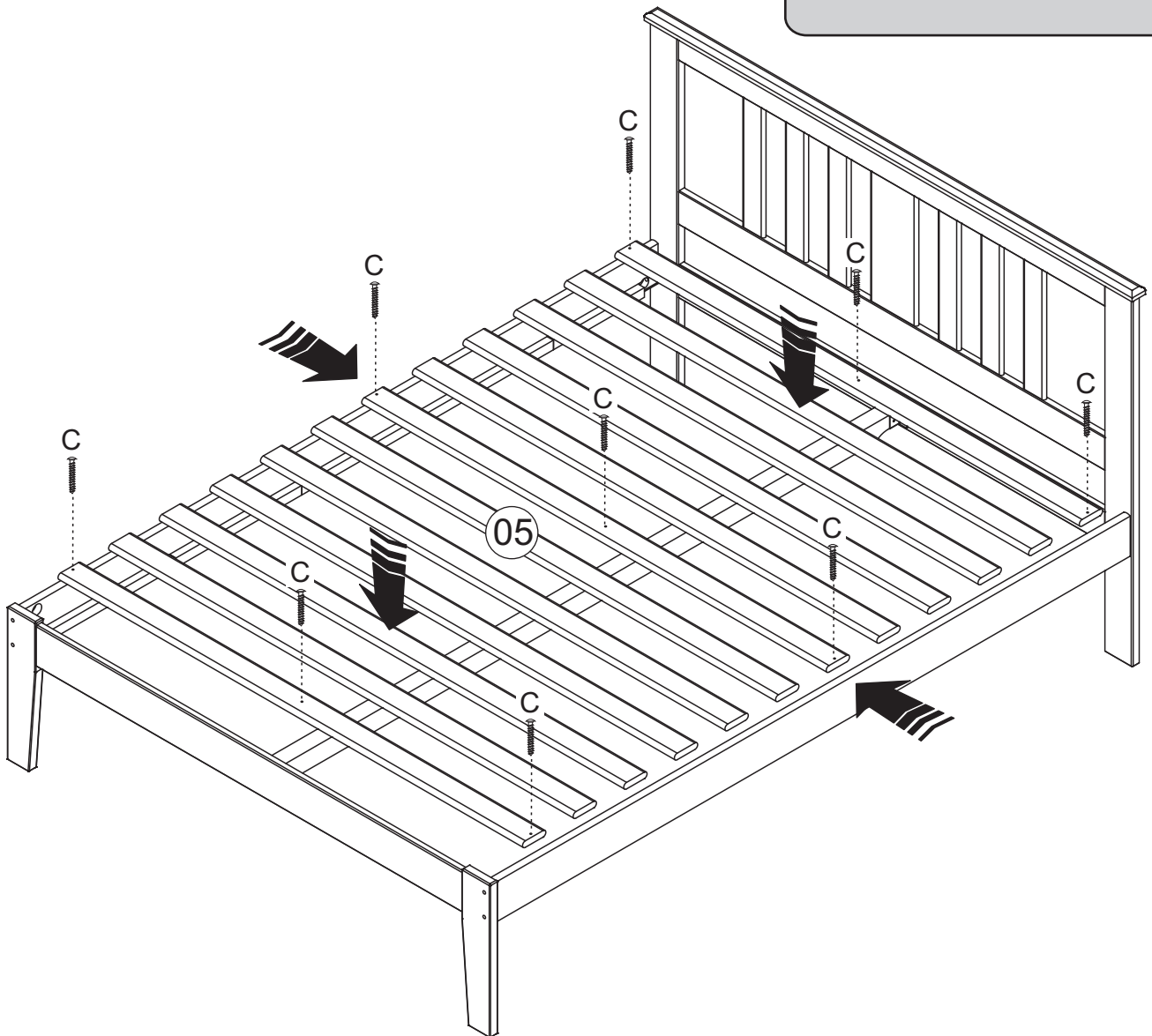

The first slats must be fixed here at 3" from each headboard end.



**C**  4,0X30 Screw

Qty  
**09**