

Size of Mattress and Foundation

The length and width of the upper bunk TWIN mattress and foundation are as follows:

Length
74"-75"

Width
37½"-38½"

Thickness
8" max

You must use only this size mattress.

Ensure thickness of mattress and foundation combined does not exceed 8"
and that the mattress is at least 5" below upper edge of guardrails.

This Bunk Bed uses a slat kit for mattress foundation.



SAFETY WARNINGS



1. Follow the information on the warnings appearing on the upper bunk end structure and on the carton. Do not remove warning label from bed.
2. Always use the recommended size mattress or mattress support, or both, to help prevent the likelihood of entrapment or falls.
3. Surface of mattress must be at least 5 inches below the upper edge of guardrails.
4. Do not allow children under 6 years of age to use the upper bunk.
5. Prohibit more than one person on upper bunk.
6. Periodically check and ensure that the guardrail, ladder, and other components are in their proper position, free from damage, and that all connectors are tight.
7. Do not allow horseplay on or under the bed and prohibit jumping on the bed.
8. Always use the ladder for entering and leaving the upper bunk.
9. Do not use substitute parts. Contact the manufacturer or dealer for replacement parts.
10. Use of a night light may provide added safety precaution for a child using the upper bunk.
11. Always use guardrails on both long sides of the upper bunk. If the bunk bed will be placed next to the wall, the guardrail that runs the full length of the bed should be placed against the wall to prevent entrapment between the bed and wall.
12. The use of water or sleep flotation mattresses is prohibited.
13. Keep these instructions for future reference.
14. **STRANGULATION HAZARD**-Never attach or hang items to any part of the bunk bed that are not designed for use with the bed; for example, but not limited to, hooks, belts and jump ropes.

Replacement parts may be obtained from any Donco dealer or directly from us at the below address

**6801 Snowden Road Fort
Worth, Texas 76140**

H A R D W A R E

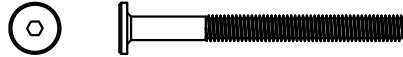

A — M6 X 100mm
ALLEN BOLT - 16 pcs

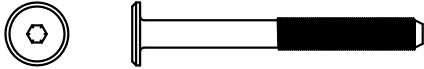

B — M6 X 70mm
ALLEN BOLT - 19 pcs

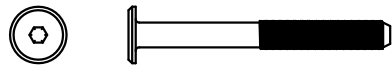

C — M6 X 60mm
ALLEN BOLT - 8 pcs



D — M6 X 30mm
ALLEN BOLT - 8 pcs

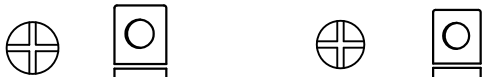

E — M6 X 16mm
CROSS DOWEL - 35 pcs **F** — M6 X 12mm
CROSS DOWEL - 8 pcs



G — Wood Dowel - 45 pcs



H — WOOD SCREW 1 1/4" - 28 pcs

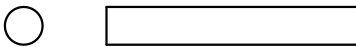

I — Metal Pin = 4pcs



J — Allen Key - 2pcs

920-A Window Bunk Bed

Assembly Instructions

Before assembling your Bunk Bed, please read through these instruction carefully, familiarising yourself with different parts

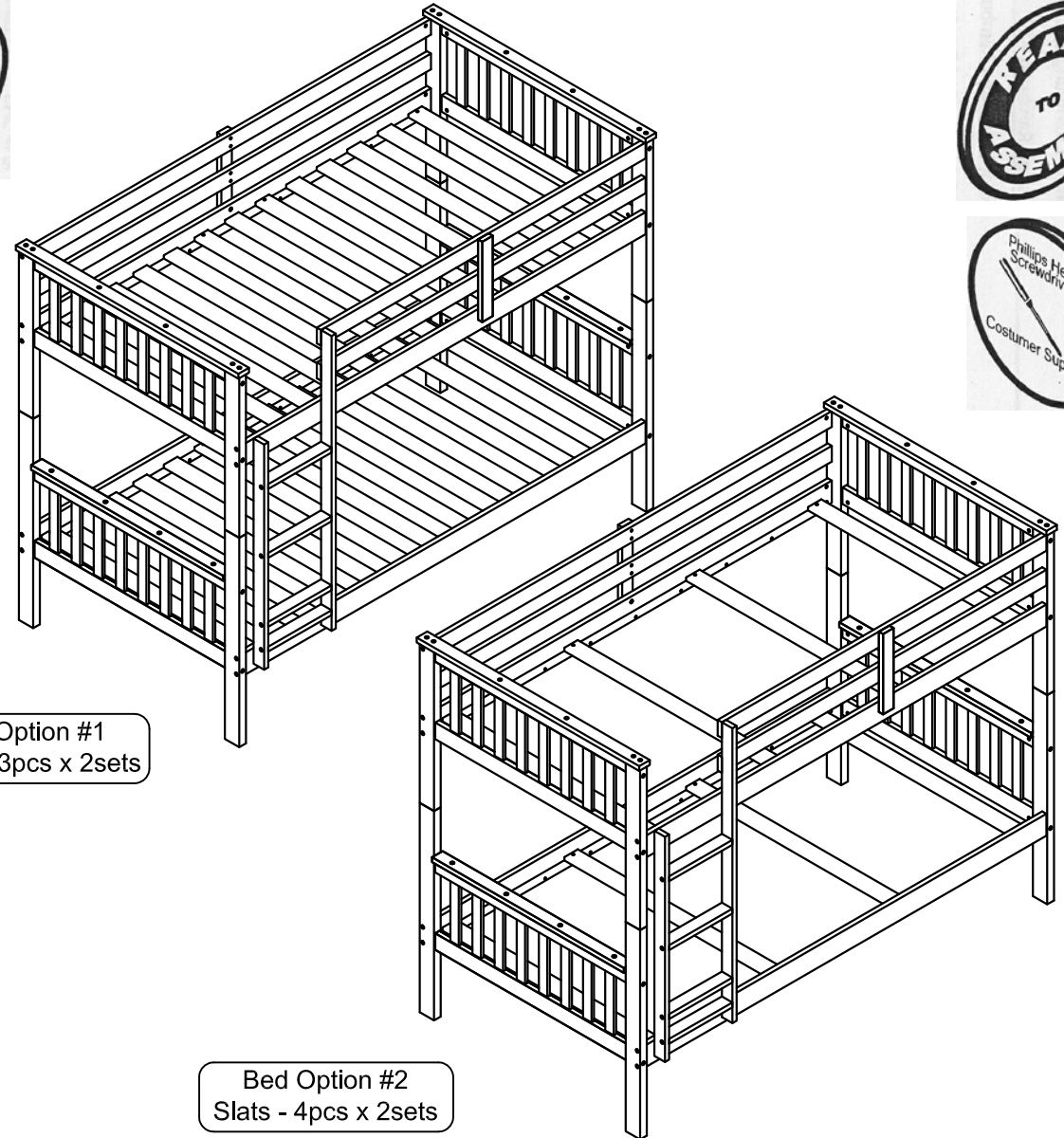
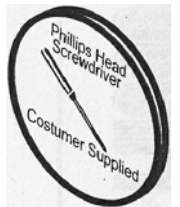

Bed Option #1
Slats - 13pcs x 2sets

Bed Option #2
Slats - 4pcs x 2sets

PART LIST

BOX 1 OF 3

- ① Top Cap Upper Bunk 2 pcs
- ② HB/FB Panel Upper Bunk 2 pcs
- ③ Left Upper Back Post 2 pcs
- Right Upper Front Post
- ④ Right Upper Back Post 1 pc
- ⑤ Left Upper Front Post 1 pc
- ⑥ Top Cap Lower Bunk 2 pcs
- ⑦ Left Lower Back Post 2 pcs
- Right Lower Front Post
- ⑧ Left Lower Front Post 2 pcs
- Right Lower Back Post
- ⑨ HB/FB Panel Lower Bunk 2 pcs

BOX 2 OF 3

- ⑩ Front / Back Vertical Rail 2 pcs
- ⑪ Top Back Guard Rail 1 pc
- ⑫ Middle Back Guard Rail 1 pc
- ⑬ Upper Back Side Rail 1 pc
- ⑭ Top Front Guard Rail 1 pc
- ⑮ Middle Front Guard Rail 1 pc
- ⑯ Upper Front Side Rail 1 pc
- ⑰ Lower Front Side Rail 1 pc
- ⑱ Lower Back Side Rail 1 pc
- ⑲ Long Ladder Rail 1 pc
- ⑳ Short Ladder Rail 1 pc
- ㉑ Ladder Step 4 pcs

BOX 3 OF 3 (Option #1)

- ㉒ Slats + Wood Screw - 16 pcs 13 pcs x 2 sets

BOX 3 OF 3 (Option #2)

- ㉒ Slats + Wood Screw - 16 pcs 4 pcs x 2 sets

Hardware
Pack

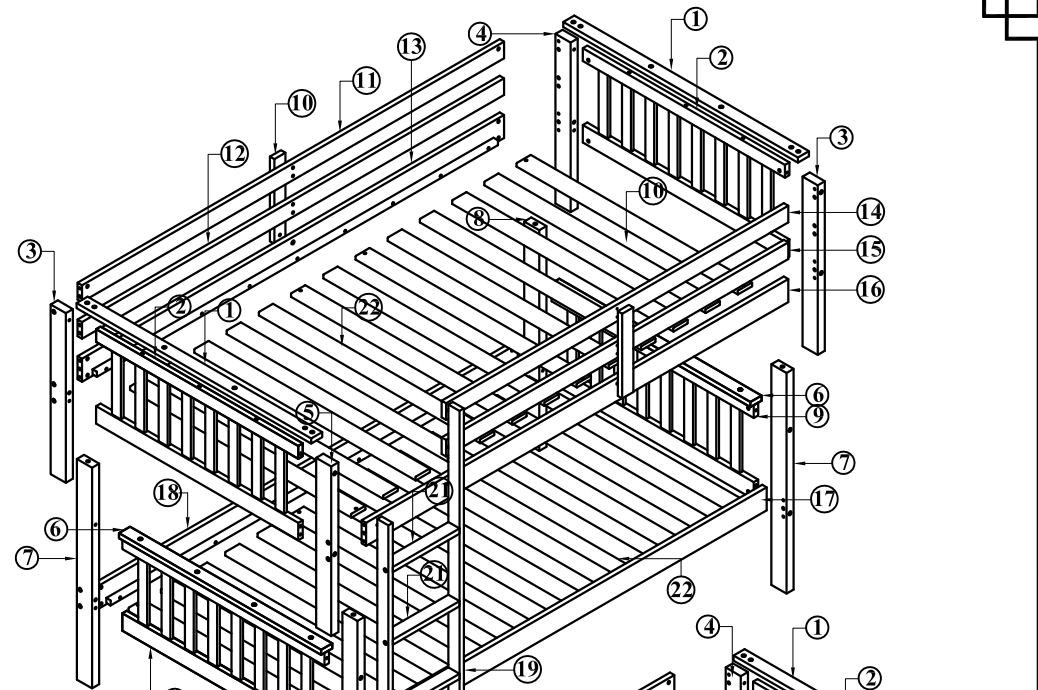

Bed Option #1
Slats - 13pcs x 2sets

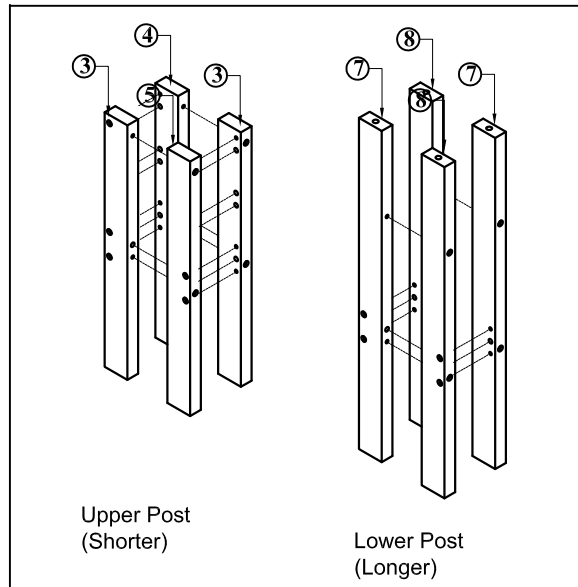

Upper Post
(Shorter)

Lower Post
(Longer)

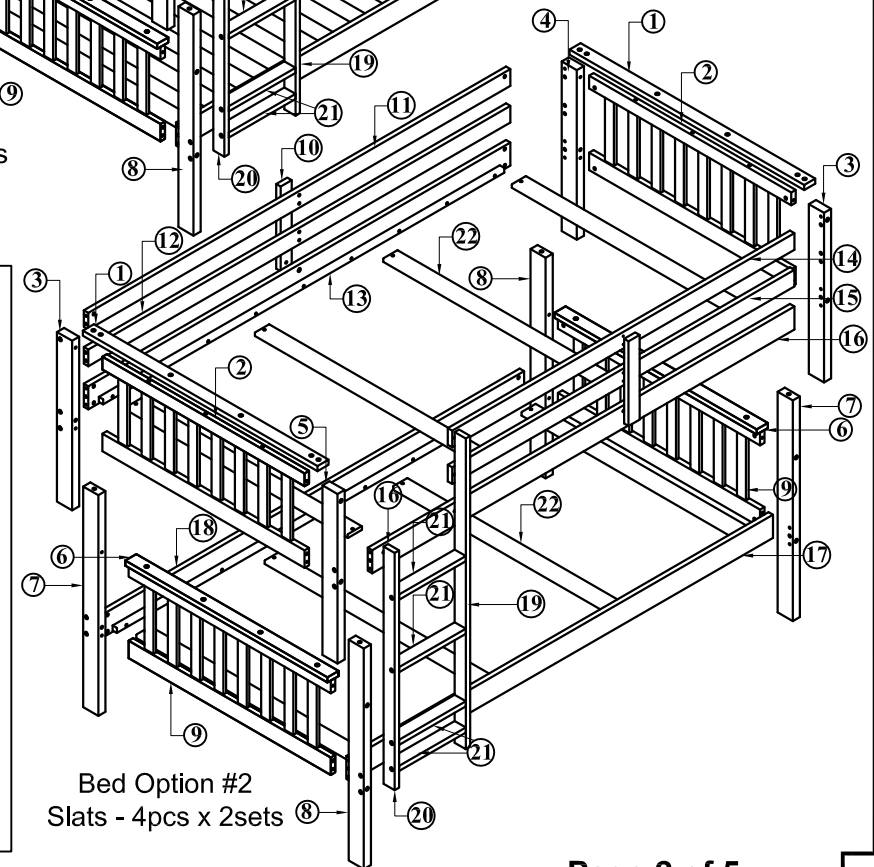

Bed Option #2
Slats - 4pcs x 2sets

STEP 1

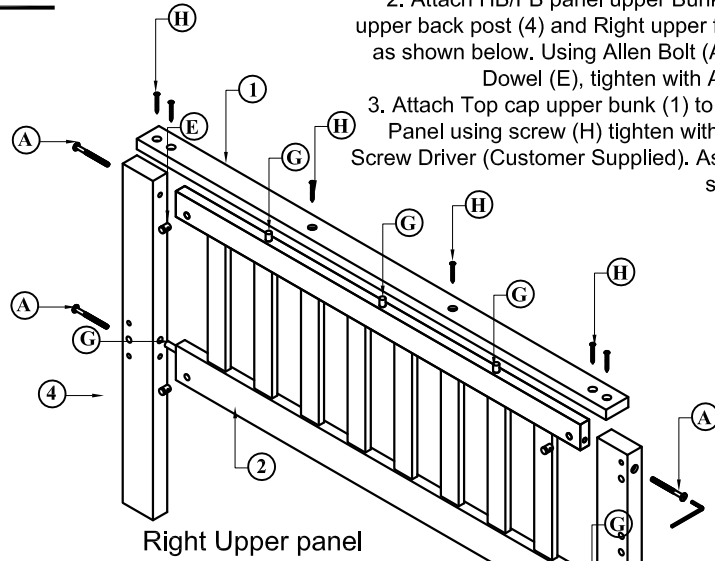

Right Upper panel

1. Tap Wood Dowel (G) to HB/FB panel upper bunk(2).
2. Attach HB/FB panel upper Bunk (2) to Right upper back post (4) and Right upper front post (3) as shown below. Using Allen Bolt (A) and Cross Dowel (E), tighten with Allen Key (J).
3. Attach Top cap upper bunk (1) to Right Upper Panel using screw (H) tighten with Philip Head Screw Driver (Customer Supplied). Assembles as shown below.

STEP 2

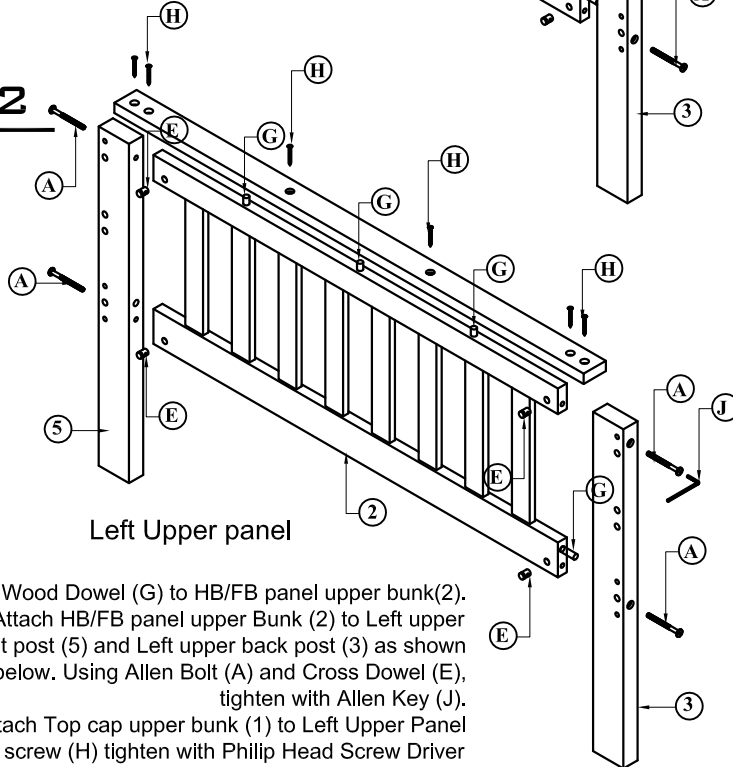

Left Upper panel

1. Tap Wood Dowel (G) to HB/FB panel upper bunk(2).
2. Attach HB/FB panel upper Bunk (2) to Left upper front post (5) and Left upper back post (3) as shown below. Using Allen Bolt (A) and Cross Dowel (E), tighten with Allen Key (J).
3. Attach Top cap upper bunk (1) to Left Upper Panel using screw (H) tighten with Philip Head Screw Driver (Customer Supplied). Assembles as shown.

STEP 3

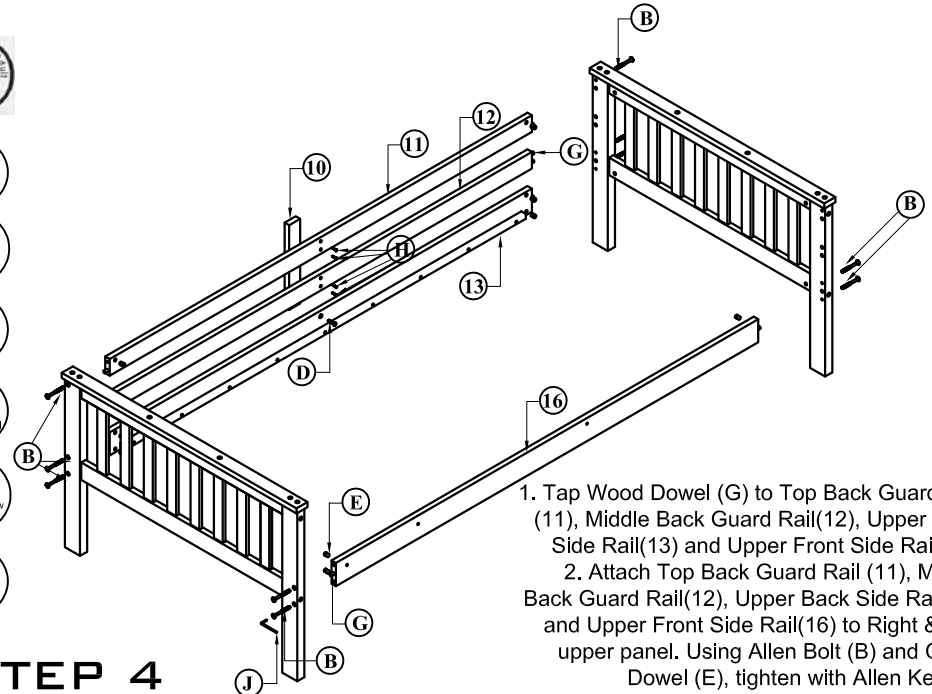

1. Tap Wood Dowel (G) to Top Back Guard Rail (11), Middle Back Guard Rail(12), Upper Back Side Rail(13) and Upper Front Side Rail(16) to Right & Left upper panel. Using Allen Bolt (B) and Cross Dowel (E), tighten with Allen Key (J).
2. Attach Top Back Guard Rail (11), Middle Back Guard Rail(12), Upper Back Side Rail(13) and Upper Front Side Rail(16) to Right & Left upper panel. Using Allen Bolt (B) and Cross Dowel (E), tighten with Allen Key (J).
3. Attach Back Vertical Rail (10) to Back Guard rail using screw (H) and Allen Bolt(D), tighten with Allen Key (J) as shown.

STEP 4

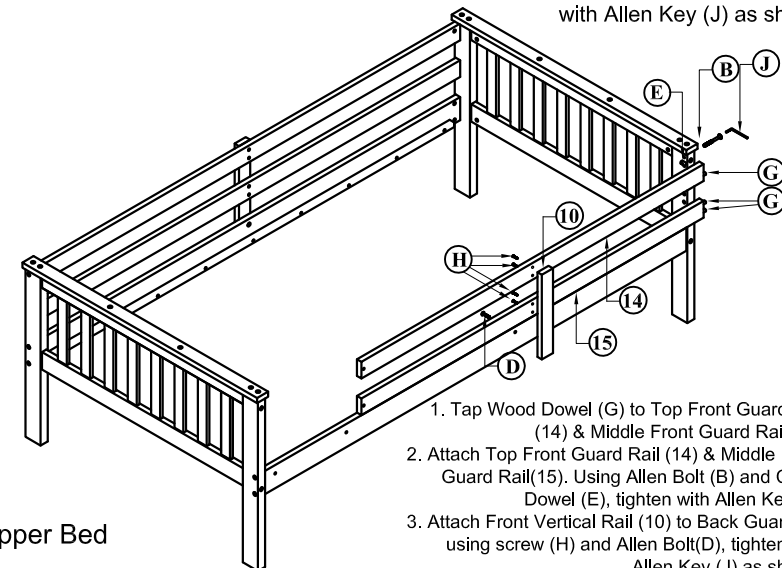

Upper Bed

1. Tap Wood Dowel (G) to Top Front Guard Rail (14) & Middle Front Guard Rail(15).
2. Attach Top Front Guard Rail (14) & Middle Front Guard Rail(15). Using Allen Bolt (B) and Cross Dowel (E), tighten with Allen Key (J).
3. Attach Front Vertical Rail (10) to Back Guard rail using screw (H) and Allen Bolt(D), tighten with Allen Key (J) as shown.

STEP 5

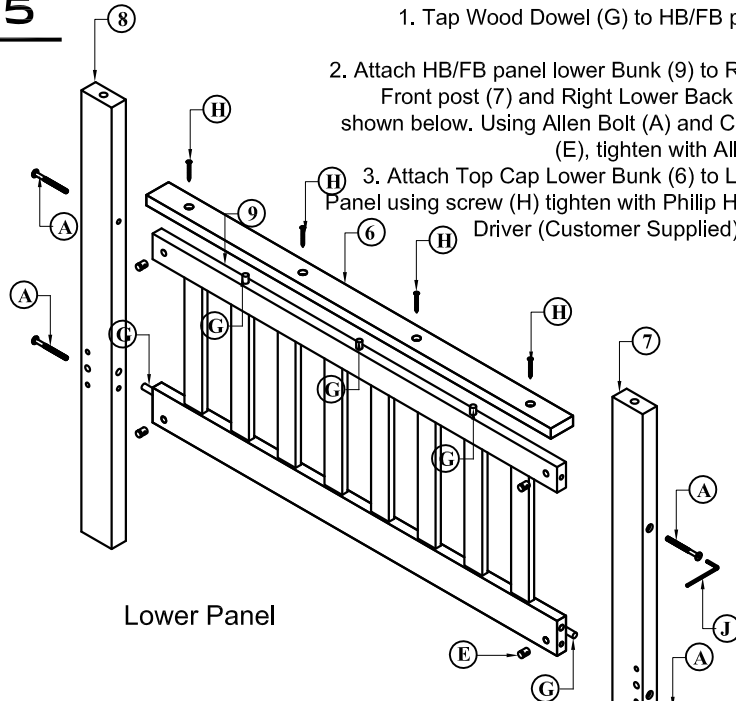

Lower Panel

1. Tap Wood Dowel (G) to HB/FB panel lower bunk(9).
2. Attach HB/FB panel lower Bunk (9) to Right Lower Front post (7) and Right Lower Back post (8) as shown below. Using Allen Bolt (A) and Cross Dowel (E), tighten with Allen Key (J).
3. Attach Top Cap Lower Bunk (6) to Lower Right Panel using screw (H) tighten with Philip Head Screw Driver (Customer Supplied) as shown.

STEP 6

1. Tap Wood Dowel (G) to Lower Front Side Rail(17) & Lower Back Side Rail (18).
2. Attach Lower Front Side Rail(17) & Lower Back Side Rail (18) to Lower panel as shown below. Using Allen Bolt (B) and Cross Dowel (E), tighten with Allen Key (J).

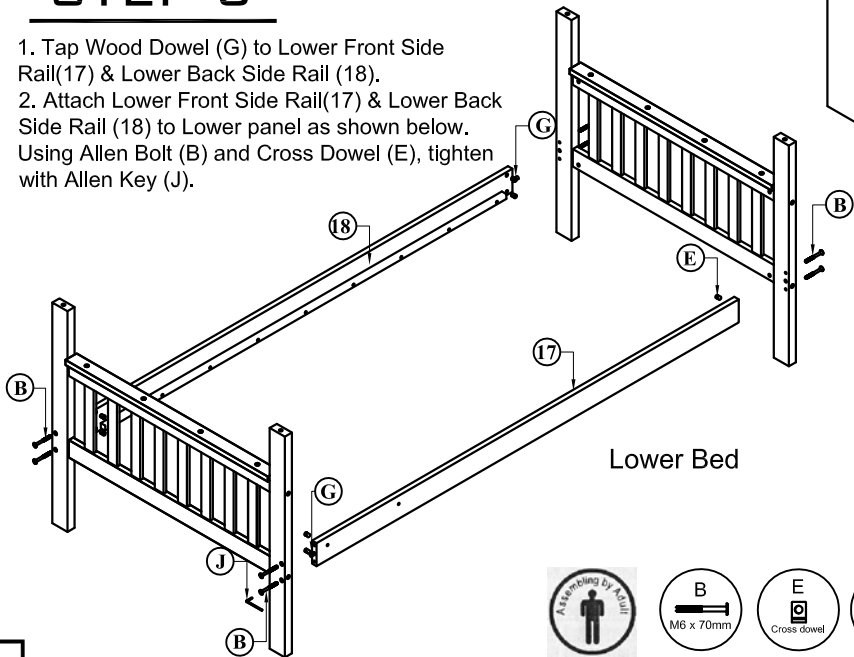

Lower Bed



STEP 7

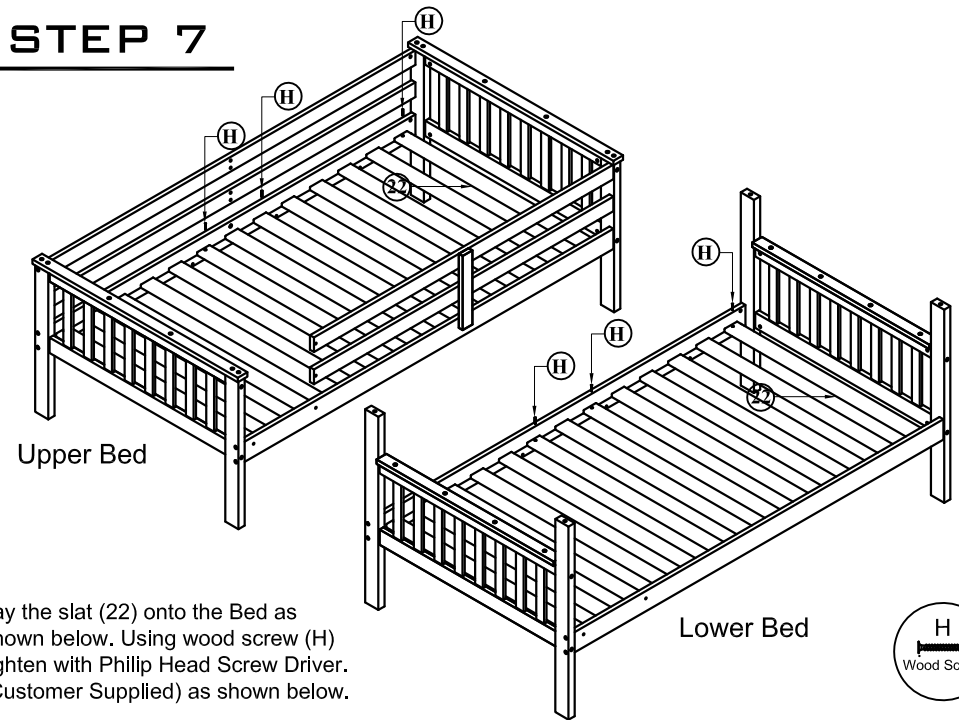

Upper Bed

Lower Bed

Lay the slat (22) onto the Bed as shown below. Using wood screw (H) tighten with Philip Head Screw Driver. (Customer Supplied) as shown below.



STEP 8

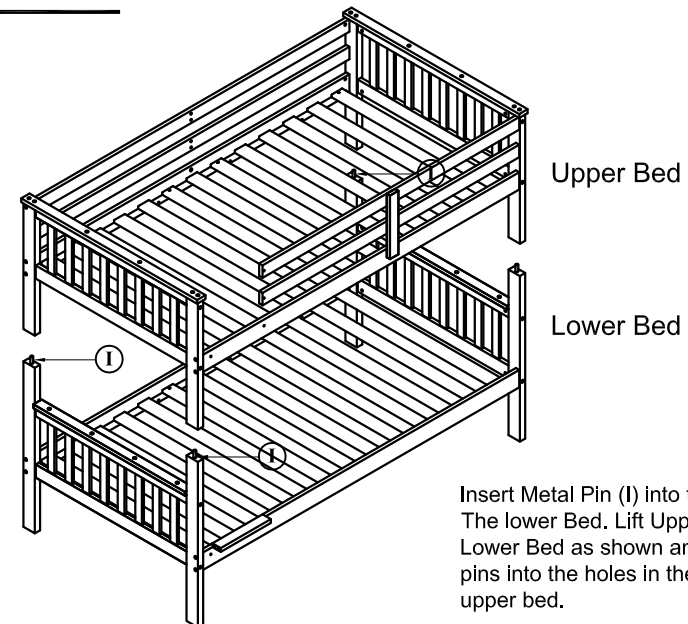

Upper Bed

Lower Bed

Insert Metal Pin (I) into the holes in top of The lower Bed. Lift Upper Bed onto the Lower Bed as shown and fit the metal pins into the holes in the bottom of the upper bed.

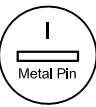

STEP 9

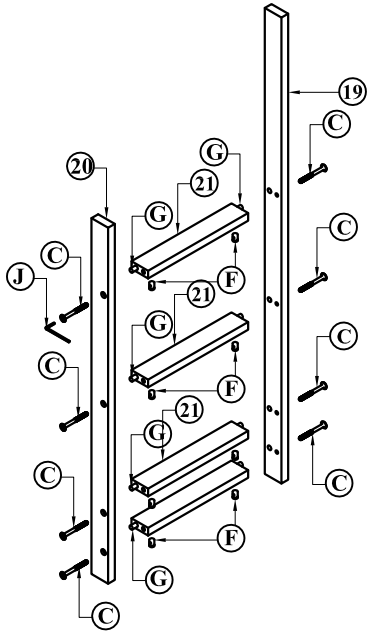

1. Tap Wood Dowel (G) to Ladder Step (21).
2. Attach Ladder Step (21) to the Long Ladder Rail (19) and Short Ladder Rail (20). Using Allen Bolt (C) and Cross Dowel (F), tighten with Allen Key (J). Assembles as shown.

STEP 10

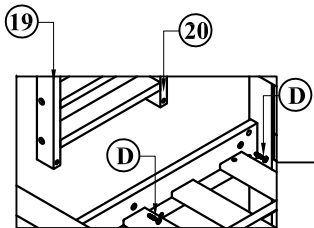
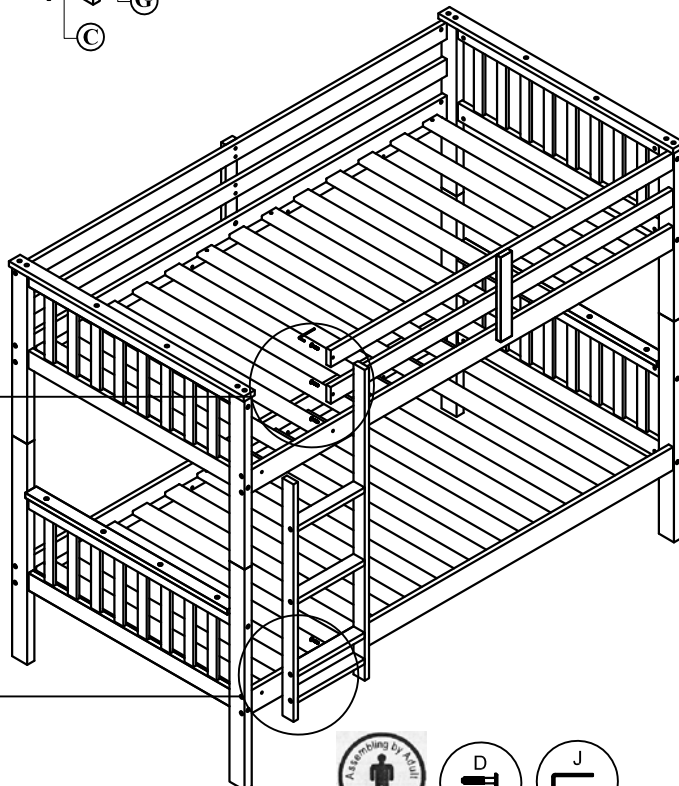
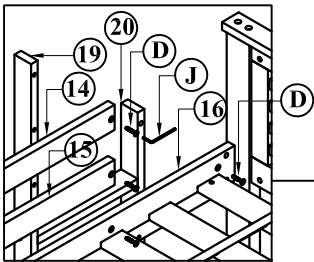

Attach Ladder to the Front Guard Rail. Using Allen Bolt (D) tighten with Allen Key (J). Assembles as shown.

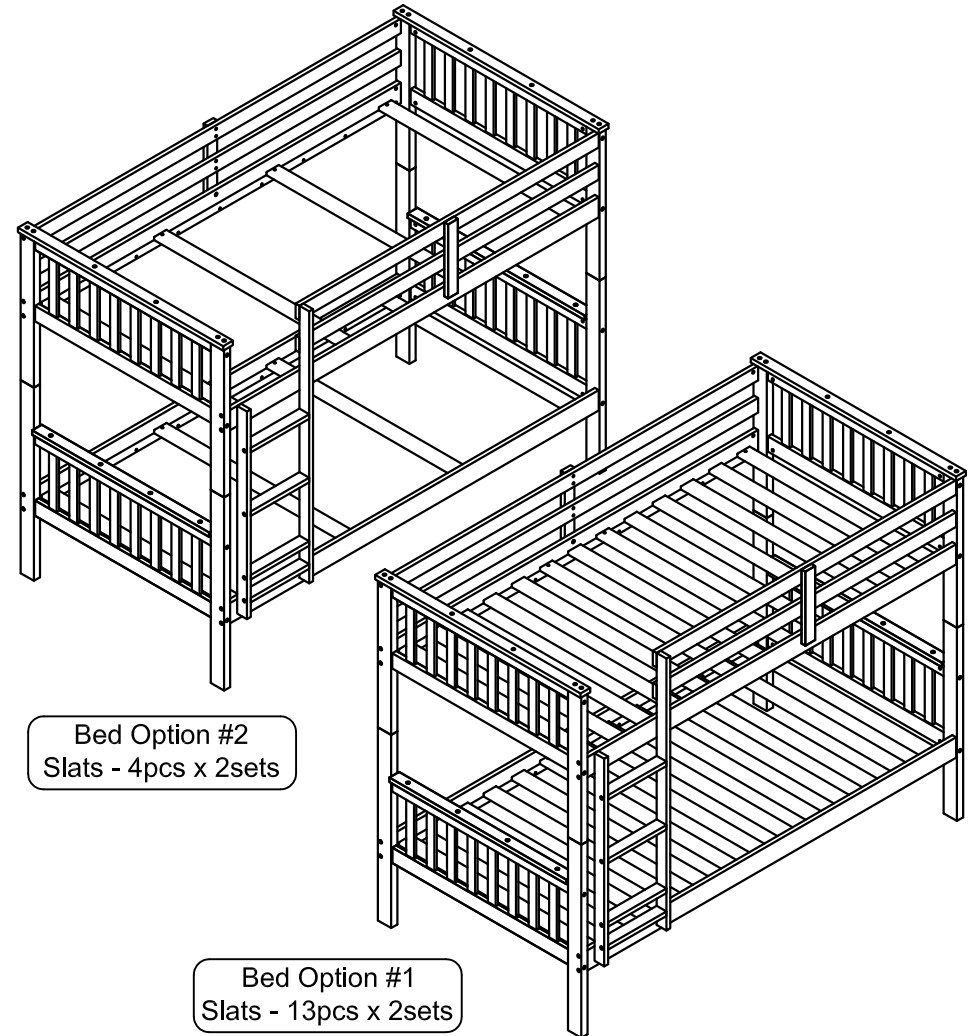

Bed Option #2
Slats - 4pcs x 2sets

Bed Option #1
Slats - 13pcs x 2sets

Congratulation!

Your 920-A Window Bunk Bed is now ready to use. We recommend that you recheck that all Bolt are tightened, and that all parts are secure before use and periodically to ensure safety