

Fix The Small Leg to Casegoods
as shown with the M8 x 100mm bolts

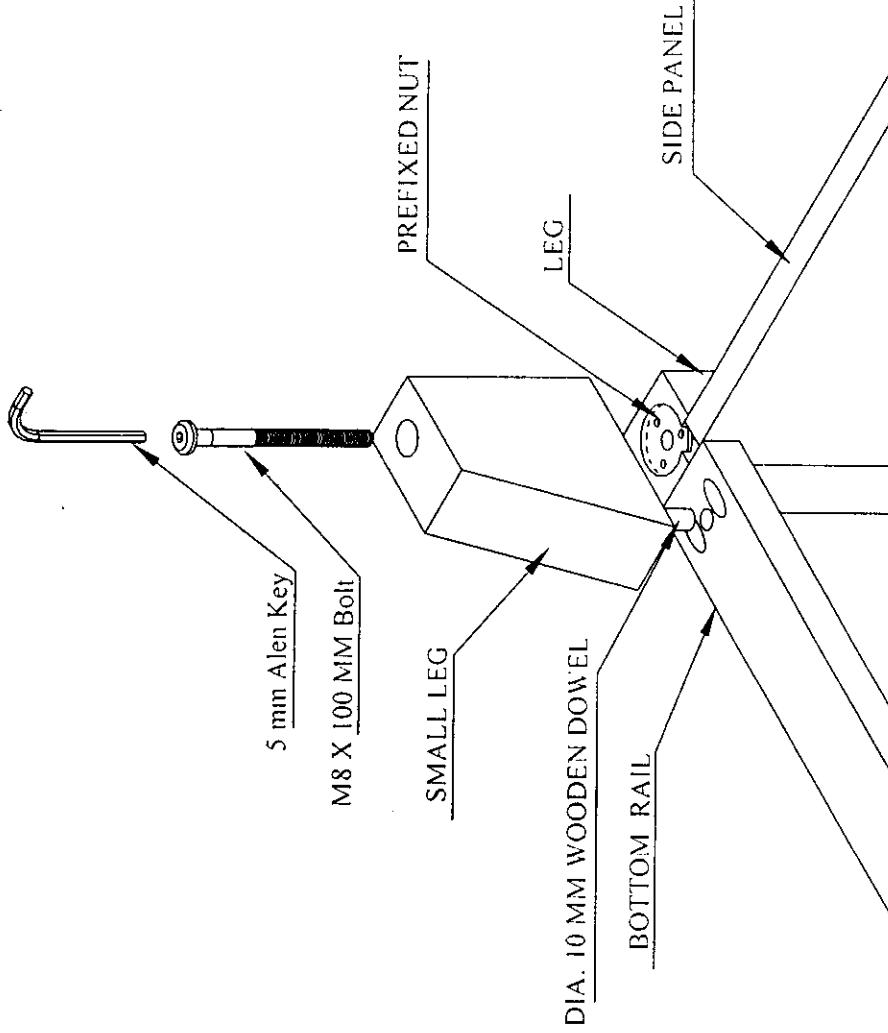

List of components
Leg - 4 pcs
Packed in first drawer

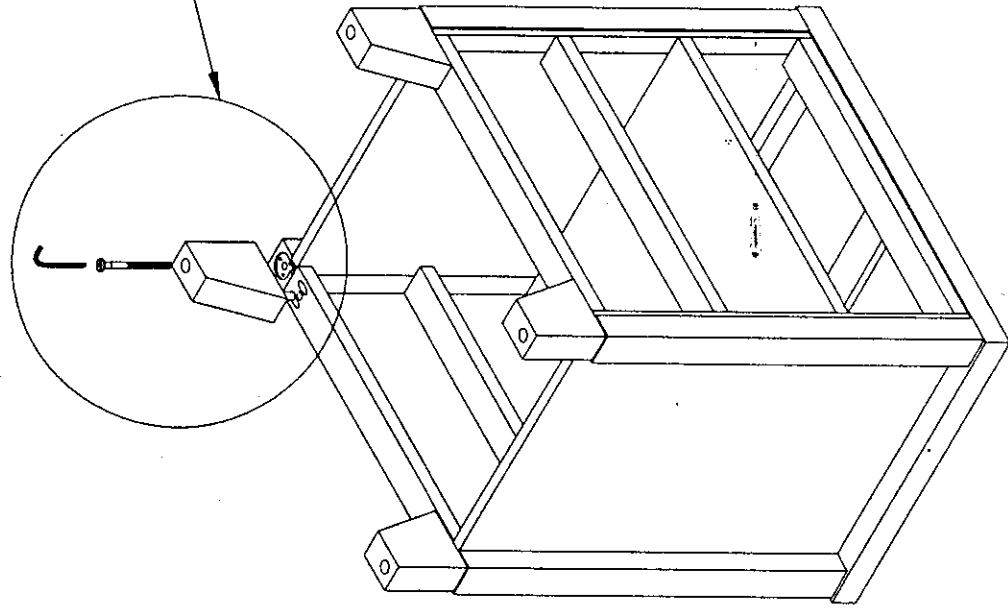
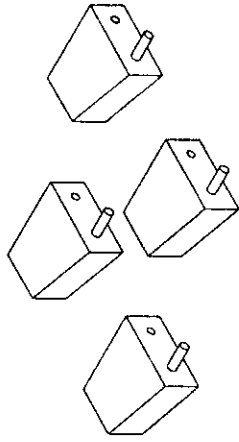

Hardware Pack in This Box # 1

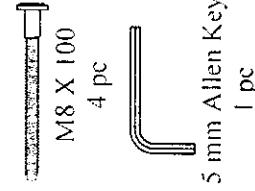

Notes
Night Stand size is shown here. Chest sizes differ only in overall size.
You Casegood style may vary from the one pictured in this assembly instruction.

ASSEMBLY INSTRUCTION PREMIUM CASEGOOD

M4 x 25

A

Metal knob

B

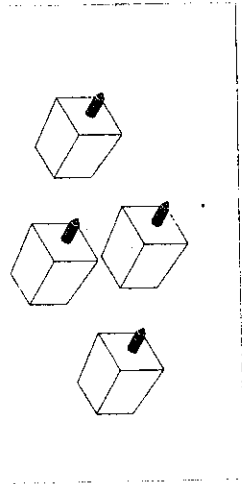
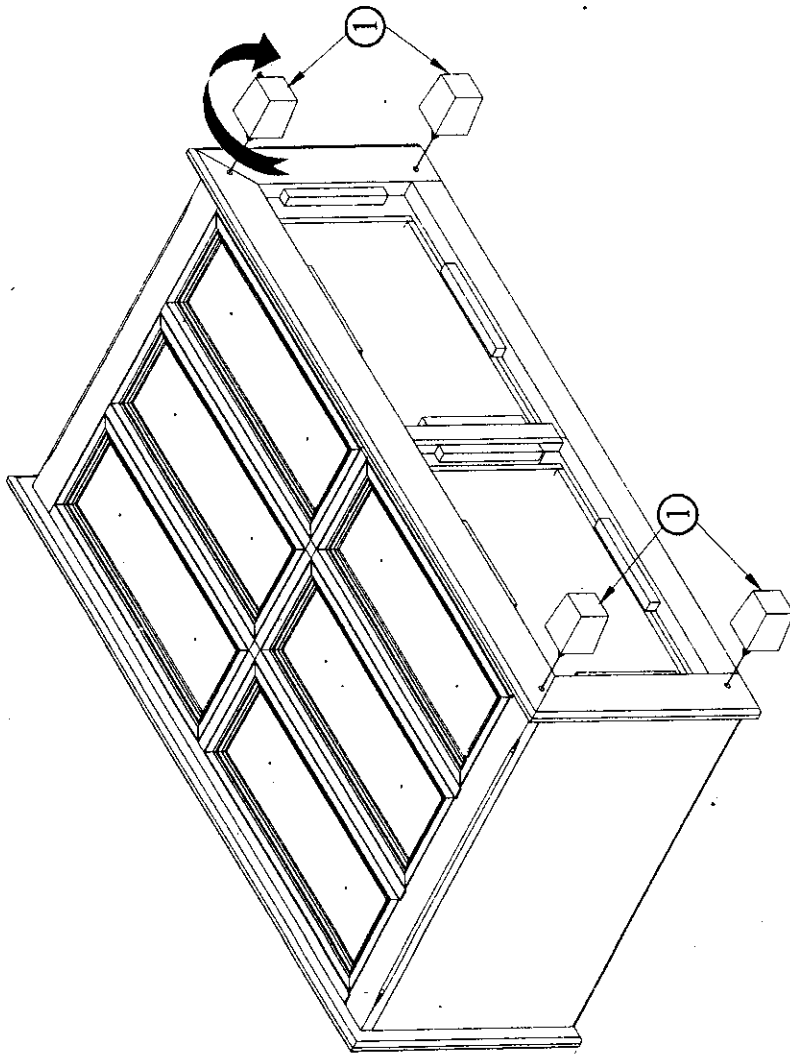
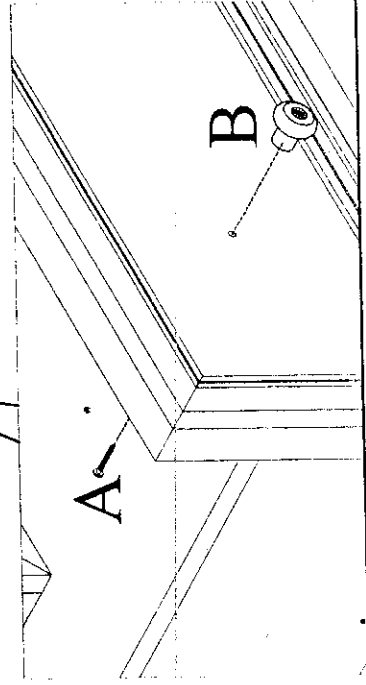
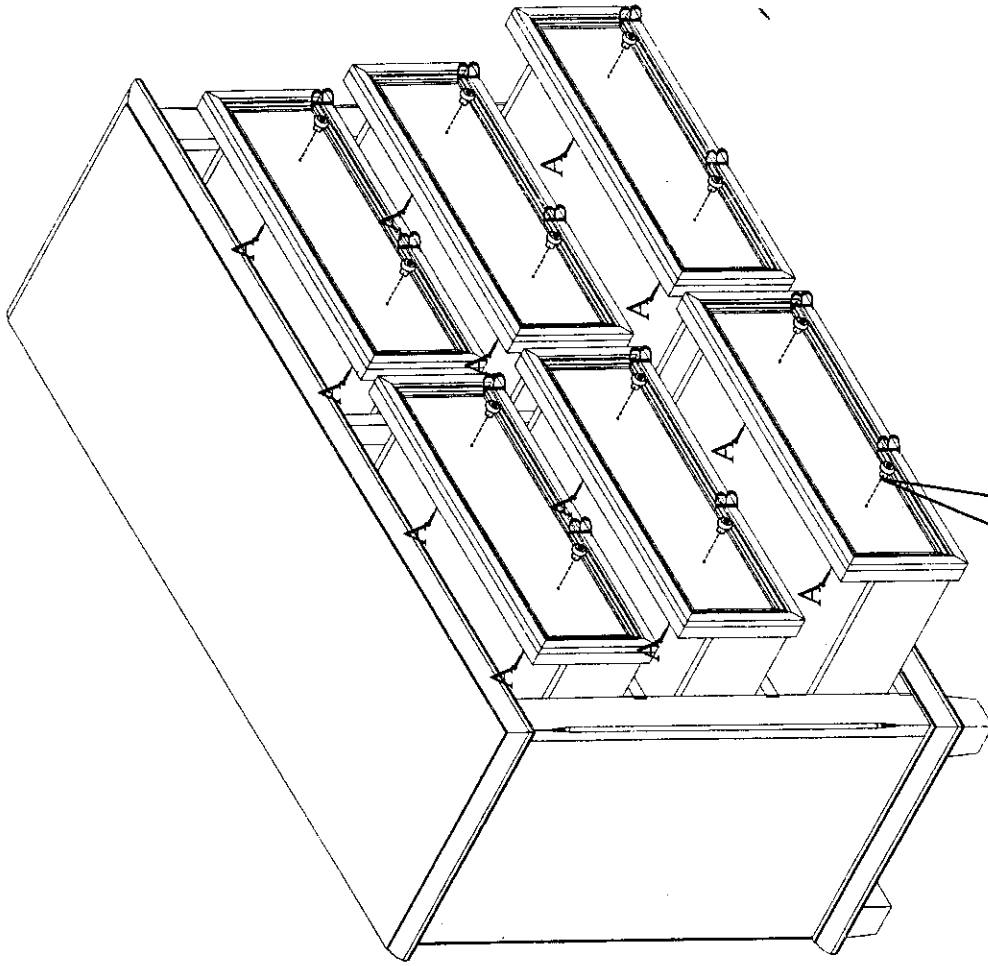

- List of components
1. Small Leg 4 pcs
Packed in First drawer

Notes:
Dresser size is shown here. Night stand and Chest sizes differ only in overall size.
Your Casegood style may vary from the one pictured in this assembly instruction

ASSEMBLY INSTRUCTION CASEGOOD PREMIUM

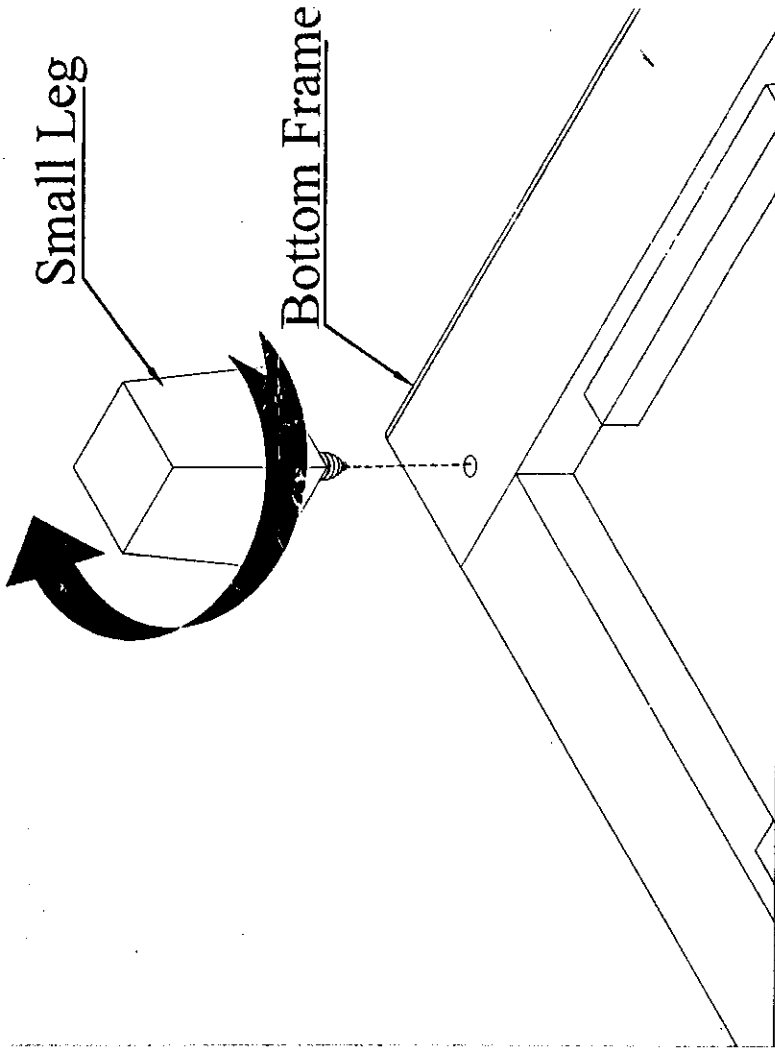
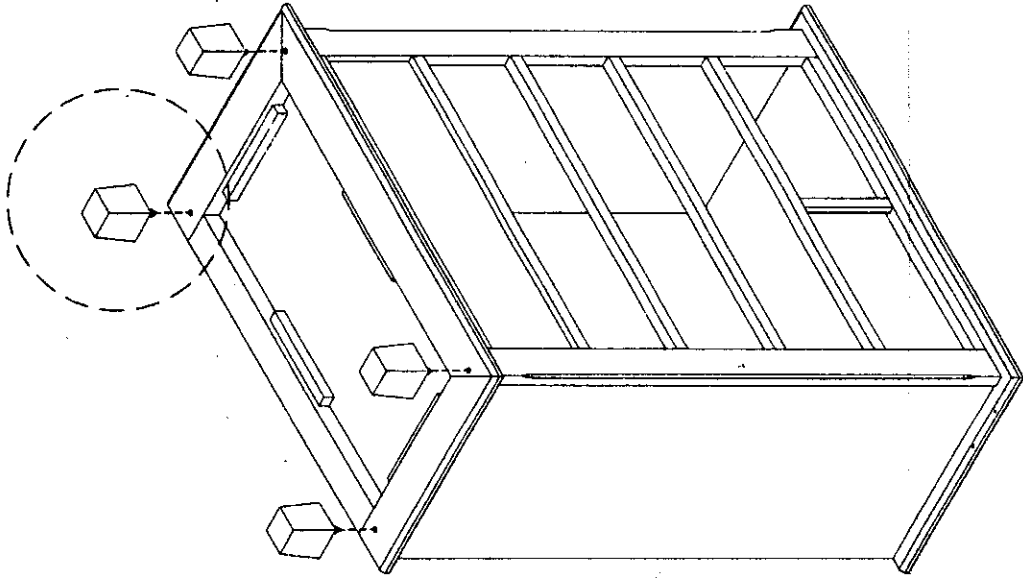

List of components
Leg 4 pcs
Packed in First drawer

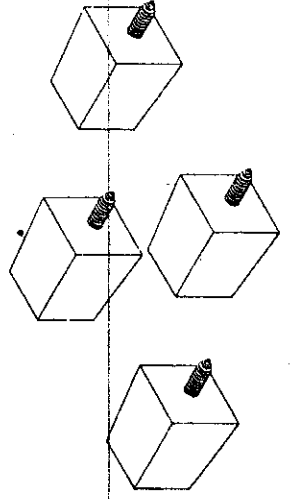

Notes:
Nighstand size is shown here. Chest sizes differ only in overall size.
You Casegood style may vary from the one pictured in this assembly instruction

ASSEMBLY INSTRUCTIONS

BENCH

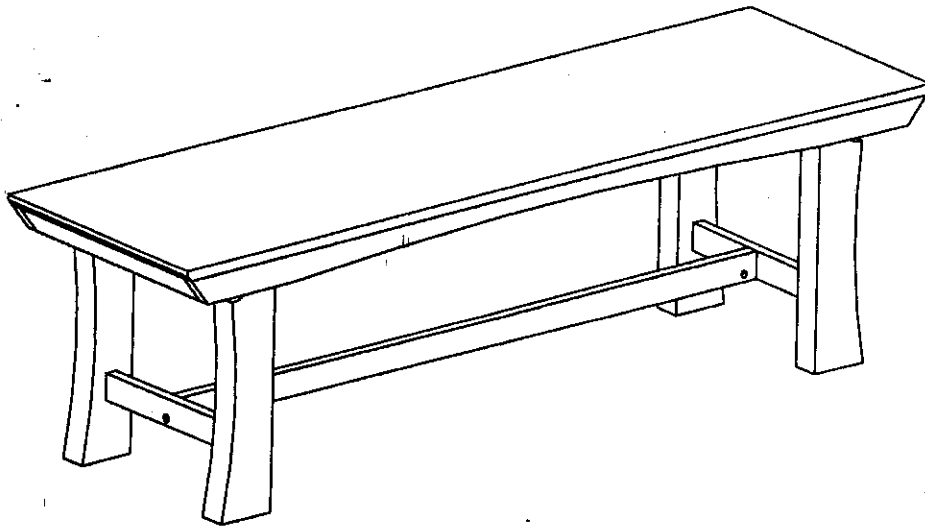

① Parts in this box

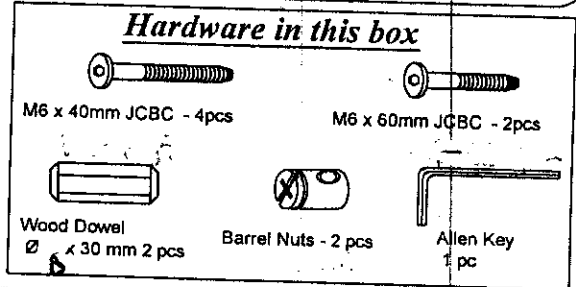
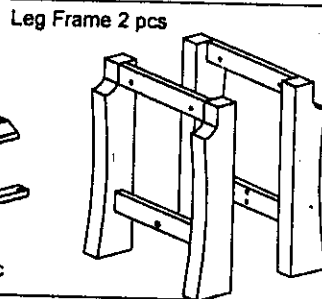
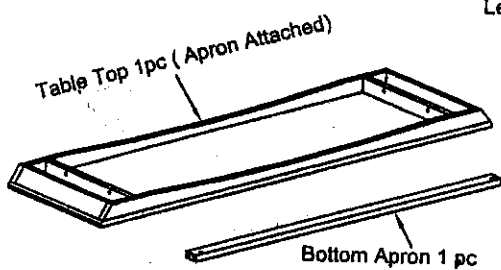

② Assembly Procedure

1. Tap the Dowel to each end of small hole bottom apron.
2. Fix the bottom apron to the leg frame using bolt M6 x 60 mm JCBC and barrel nut.
3. Turn the table top frame upside down as shown on diagram. Be sure that the table top frame is laying on flat smooth surface.
4. Attach the Leg Frame to the table top frame using 40 mm JCBC bolts

Helpful Tips : Fastening of bolts

- Check that all holes are free of wood chips and sawdust.
- A screwdriver will help in aligning the Barrel Nut hole with the Bolt.

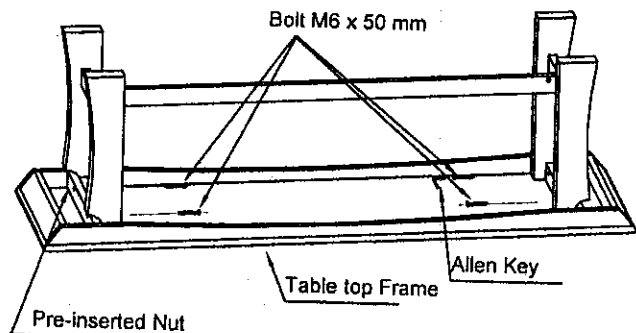
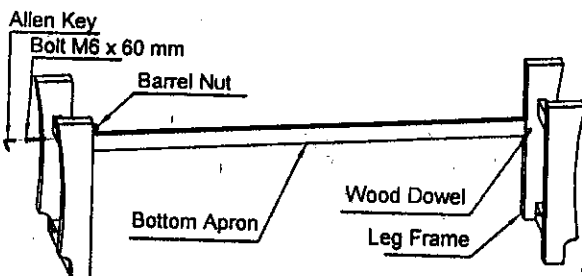
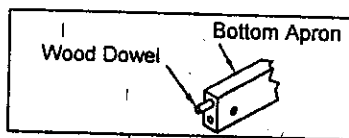

This assembly instruction shows coffee table assembly. Procedure is the same for both sizes.

1 Parts in this box

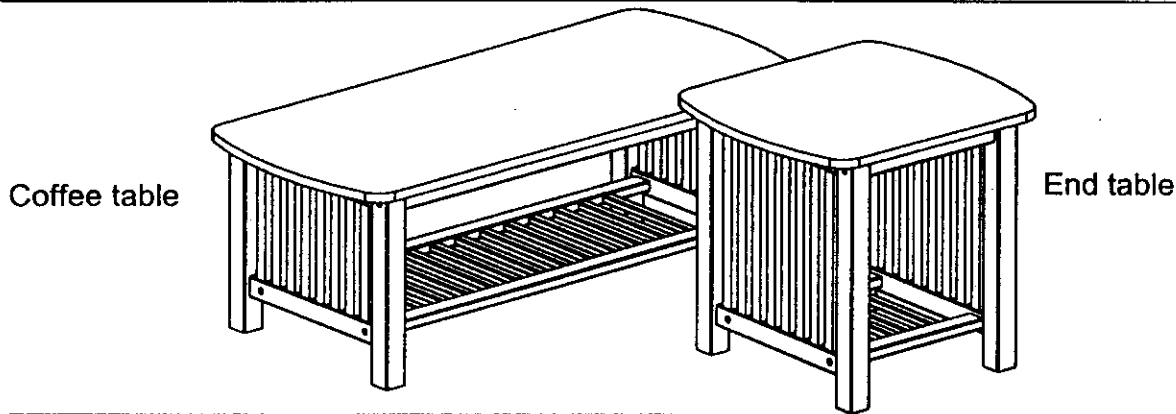

2 Parts in this box

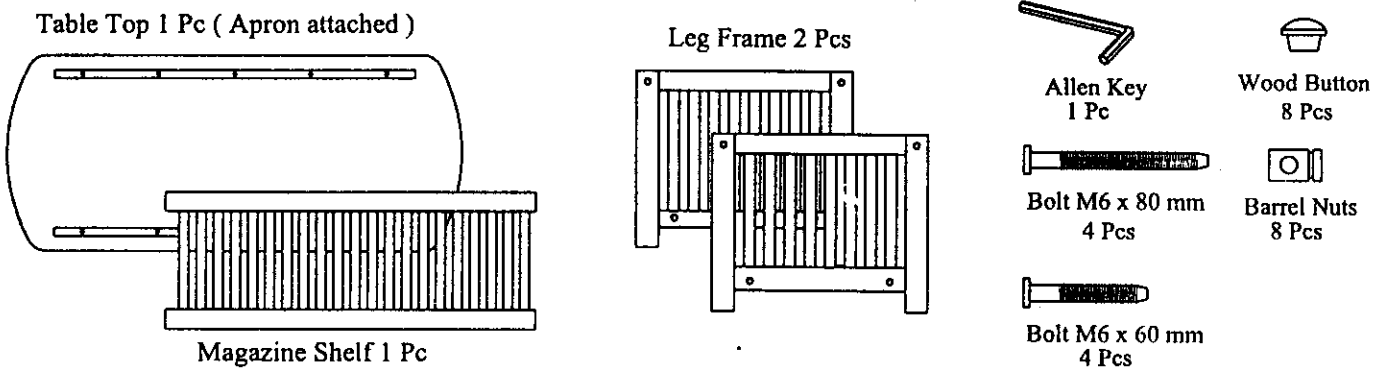

3 Assembly Procedure

1. Turn the Table Top upside down as shown on diagram. Be sure that the Table Top is laying on a smooth flat surface.
2. Attach the Leg Frames to the Apron using the Longer Bolts and Barrel Nuts. -LEAVE BOLTS VERY LOOSE !!
3. Fix the Shelf Frame to the Leg Frame using the Shorter Bolts and Barrel Nuts.
4. When all parts are assembled, gently tighten all the Bolts. Finally lightly tap the Wood Buttons in to the bolt holes.

Helpful Tips ; Fastening of Bolts

- ✓ Check that all holes are free of wood chips and sawdust.
- ✓ A screwdriver will help in aligning the Barrel Nut hole with the Bolt.
- ✓ Screw the Bolt in gently the avoid stripping the threads.

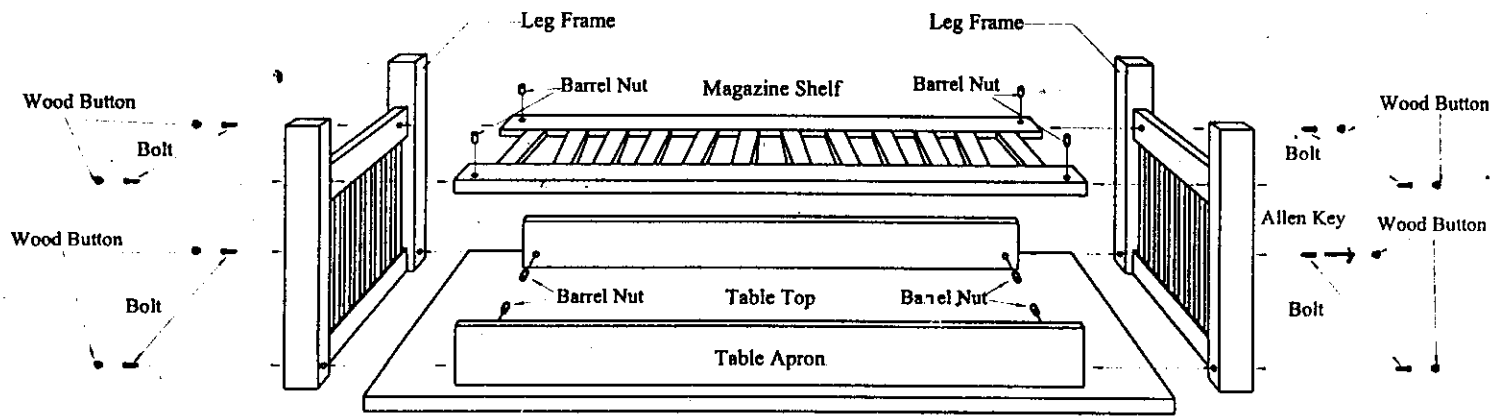

BAHAMA TABLE

ASSEMBLY INSTRUCTIONS

1 One pair of Table

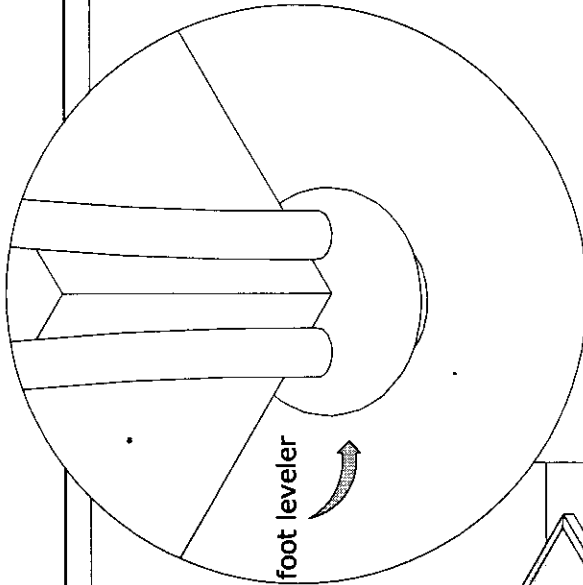
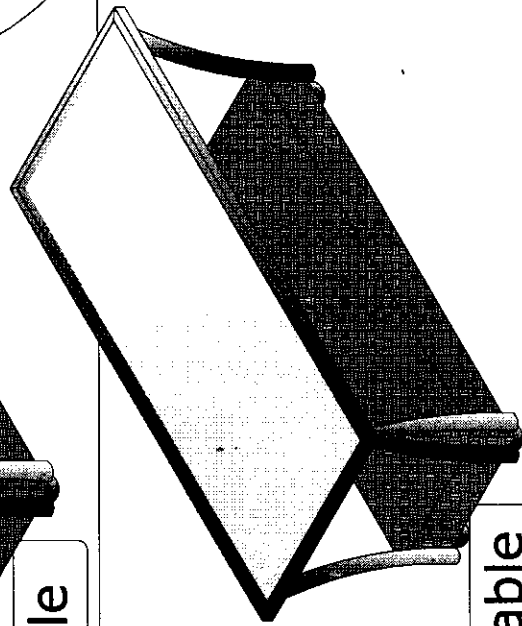
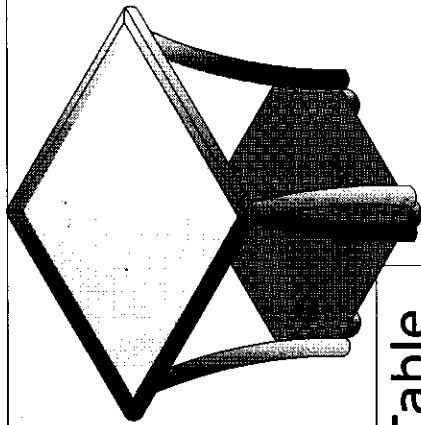

Step 1

Turn the adjustable foot leveler, to level the fasten position

Step 2

Fix the glass table top on to the table frame

Table Top Glass

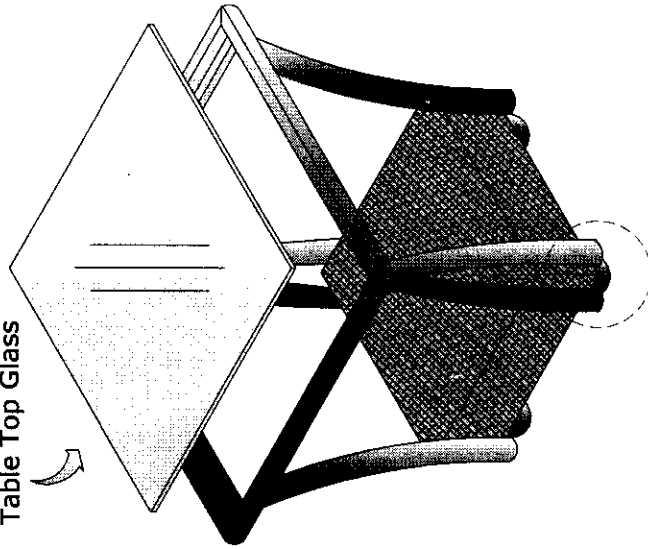

i The table top glass is packed inside a separate box

DRAWER

ASSEMBLY INSTRUCTIONS

Hardware for Assembly



JCB Screws 60 mm

- A** 3 pcs for chair
3 pcs for lounge twin & full
6 pcs for full & queen



JCB Screws 18 mm

- B** 4 pcs for chair
4 pcs for lounge twin & full
8 pcs for full & queen



Barrel nuts

- C** 3 pcs for chair
3 pcs for lounge twin & full
6 pcs for full & queen



Washer

- D** 4 pcs for chair
4 pcs for lounge twin & full
8 pcs for full & queen

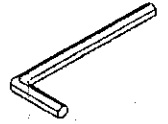

Allen Key

- E** 1 pc for All size

Parts Per Drawer

Chair & Lounge Twin/full size - One Drawer
Full & Queen Size - Two Drawer

1. Front Panel 1 Pc for Chair
1 Pc for Lounge Twin & Lounge Full
2 Pcs For Full & Queen
1. Side Panel 2 Pcs for Chair
2 Pcs for Lounge Twin & Lounge Full
4 Pcs For Full & Queen

3. Back Panel 1 Pc for Chair
1 Pc for Lounge Twin & Lounge Full
2 Pcs For Full & Queen
4. Bottom Brace .. 1 Pc for Chair
1 Pc for Lounge Twin & Lounge Full
2 Pcs For Full & Queen
5. Bottom Panel ... 1 Pc for Chair
1 Pc for Lounge Twin & Lounge Full
2 Pcs For Full & Queen

1. Step

Fit the side Panels to the Back Panel, use 60mm Bolts to attach Side panel in place, but don't fully tighten these yet.

Attach Bottom Brace to Back Panel, use 60mm Bolt and Barrelnut as shown.

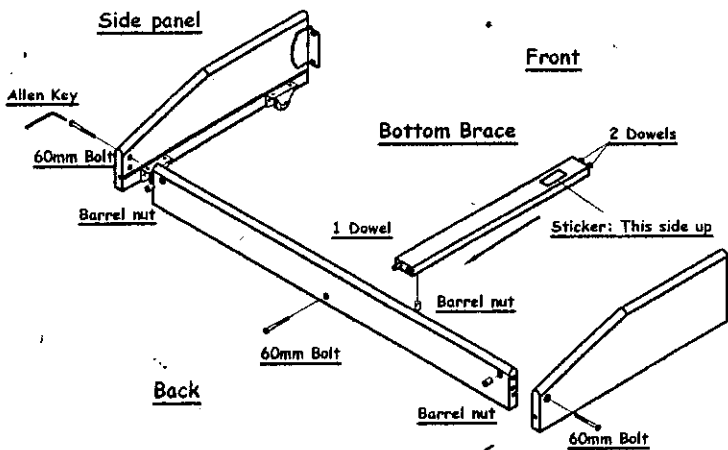

2. Step

Slide in the bottom panel as shown along the grooves on the side panels.

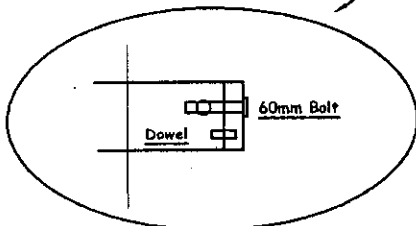
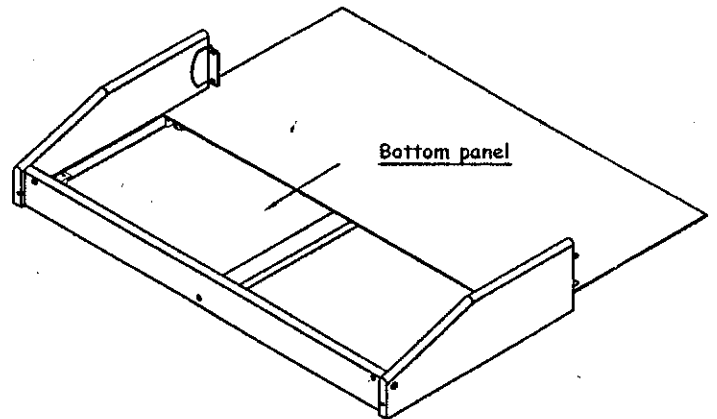

Don't fully tighten the bolt, leave them a bit loose, to make fitting the front panel easier

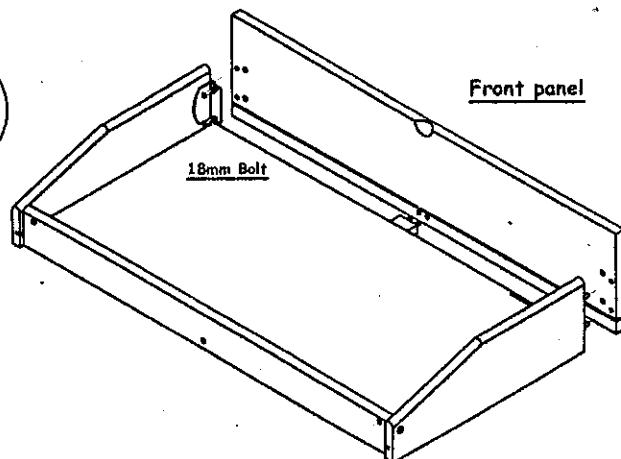

3. Step

Fit the side panels to the drawer front, fitting dowels in the holes. Use two 18mm bolts to attach the side panel in place.

1 Assembled view

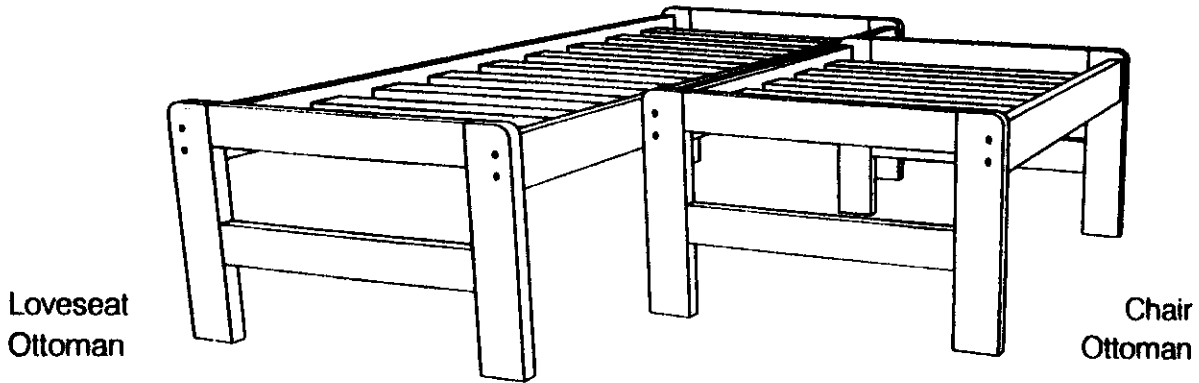

2 Parts in this box

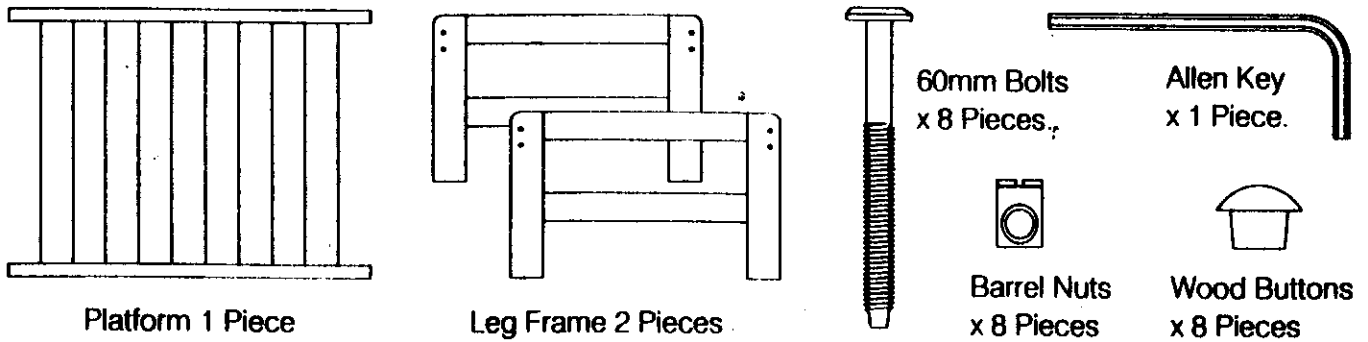

3 Assembly Procedure

1. Turn Ottoman Platform upside down as shown on diagram. Be sure that the Platform is laying on a flat smooth surface.
2. Attach Leg Frame to the Side rails using Bolts and Barrel nuts. - LEAVE BOLTS VERY LOOSE!
3. When all parts are assembled, gently tighten all the Bolts to secure all parts.
4. Finally, push or gently tap Wood Buttons into the Bolt Holes

Helpful Tips: Fastening of Bolts

- ✓ Check that all holes are free of wood chips and sawdust.
- ✓ A screwdriver will help in aligning the Barrel Nut hole with the Bolt.
- ✓ Screw the Bolt in gently to avoid stripping the threads.

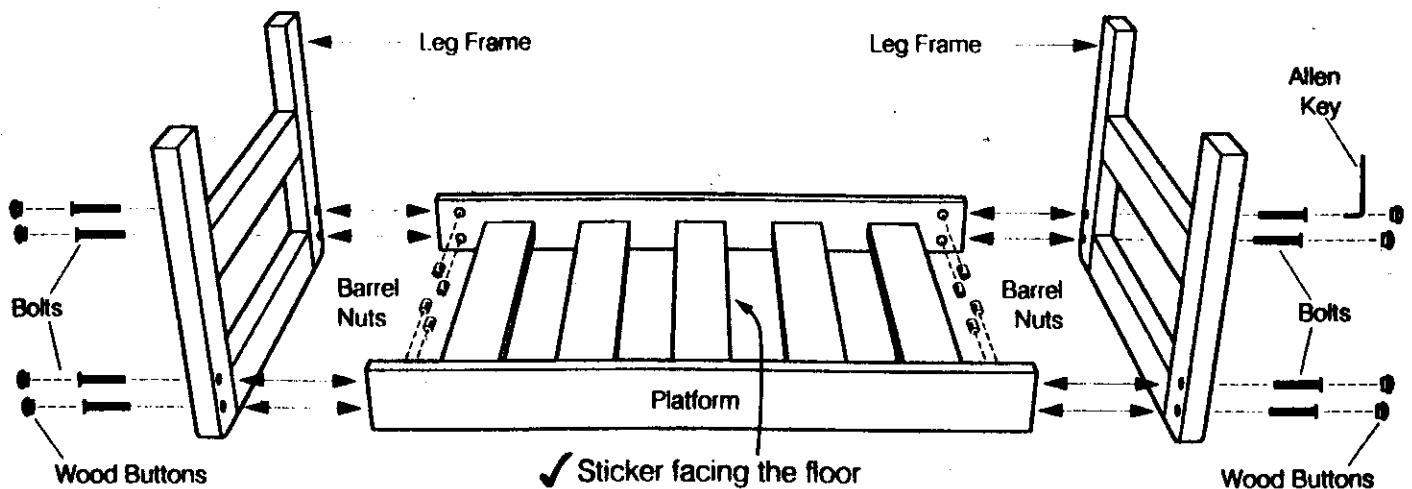

Ultra Mirror Frame

Assembly Instructions

Fixing Mirror Frame onto the Casegood

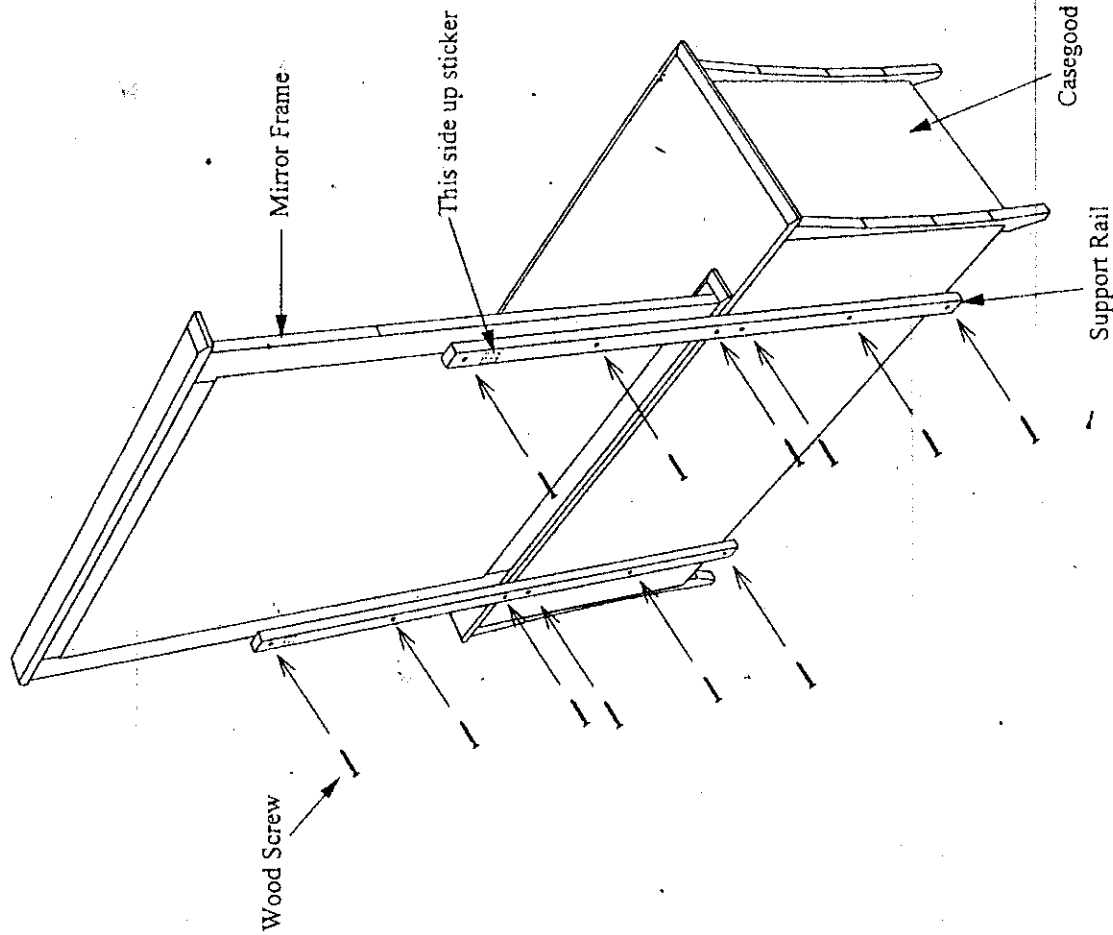

Parts

This side up sticker

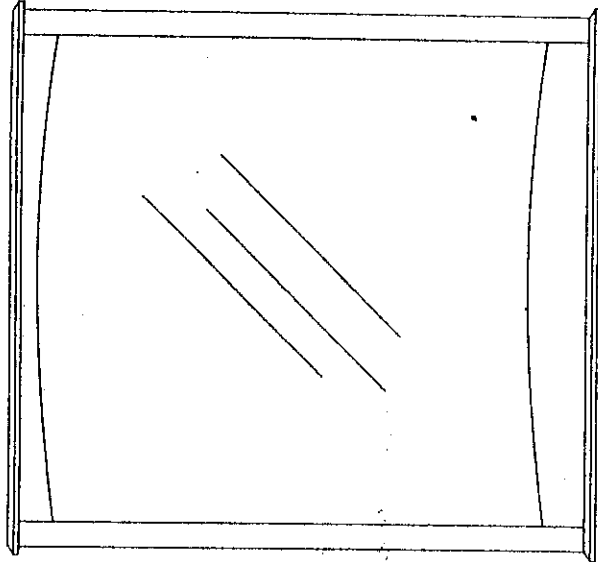

Mirror Frame

Support Rail

Hardware

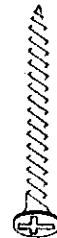

Wood Screw - 12pcs.

KYOTO MIRROR FRAME

Please remove the hooks that are attached on the mirror if you want to change the hanging position from potrait to landscape. To change hook position, use predrilled hole as shown below.

Use Philip screw driver to remove hook and reattach accordingly.

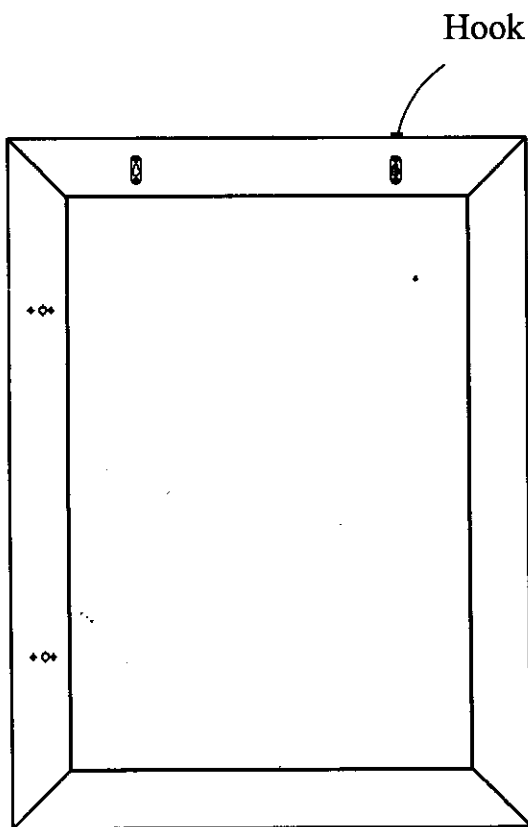
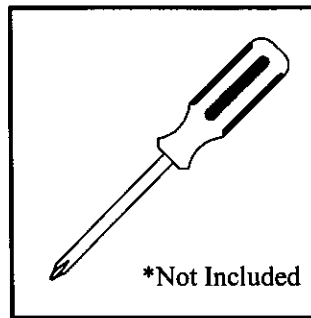

Fig. 1 : Potrait Position.

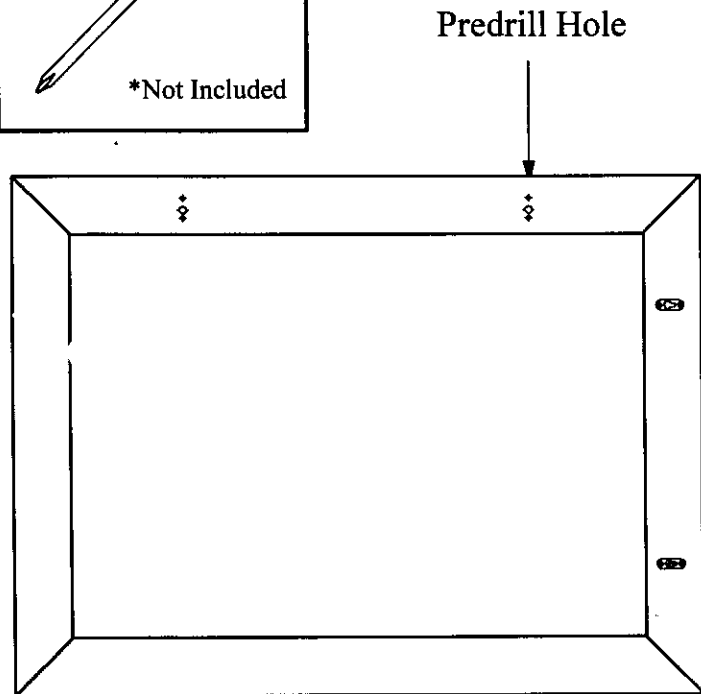

Fig. 2 : Landscape Position

AMSTERDAM MIRROR FRAME

Please remove the hooks that are attached on the mirror if you want to change the hanging position from potrait to landscape. To change hook position, use predrilled hole as shown below.

Use Philip screw driver to remove hook and reattach accordingly.

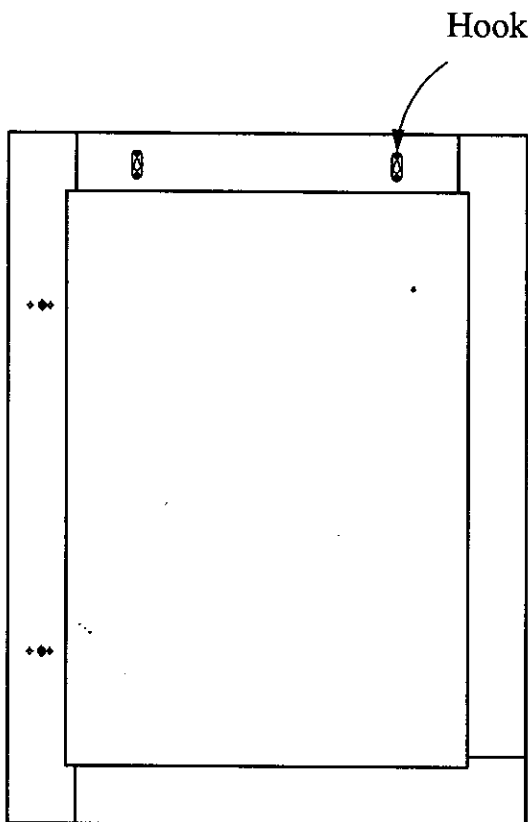
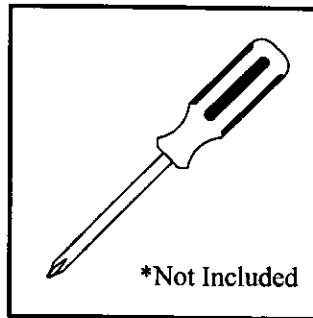

Fig. 1 : Potrait Position

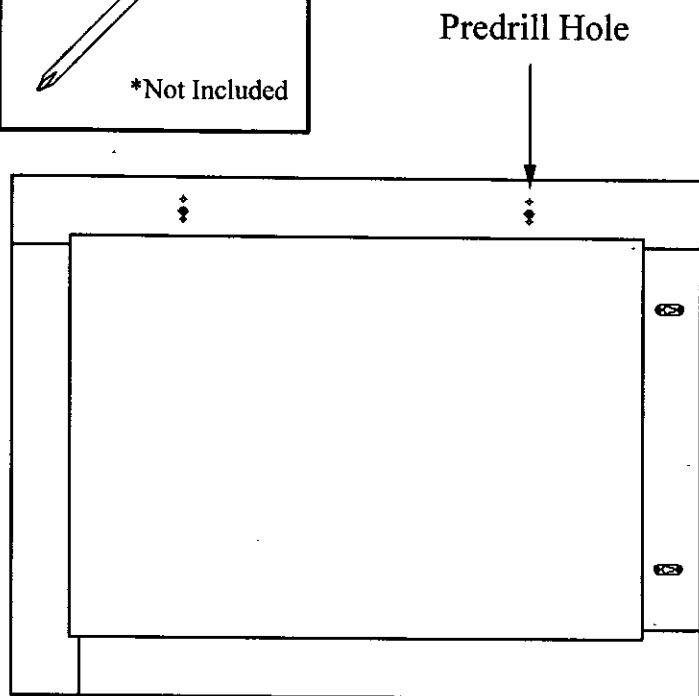

Fig. 2 : Landscape Position