

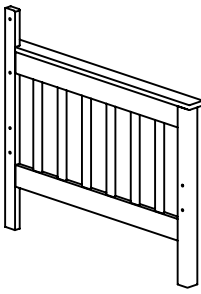

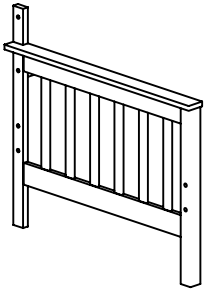



ASSEMBLY INSTRUCTION

MISSION DAYBED

Model # 420

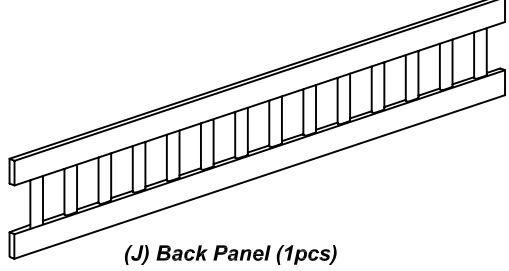
HARDWARE LIST				PART LIST	
Part	Qty	Description	Picture		
A	8	Allen Bolt Ø 6 x 45		 	
B	8	Spring Washer			
C	8	Flat Washer			
D	8	Hex nut			
E	1	Allen key M4			
F	1	Open end Wrench			
G	4	Allen Bolt Ø 6 x 75			

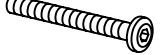
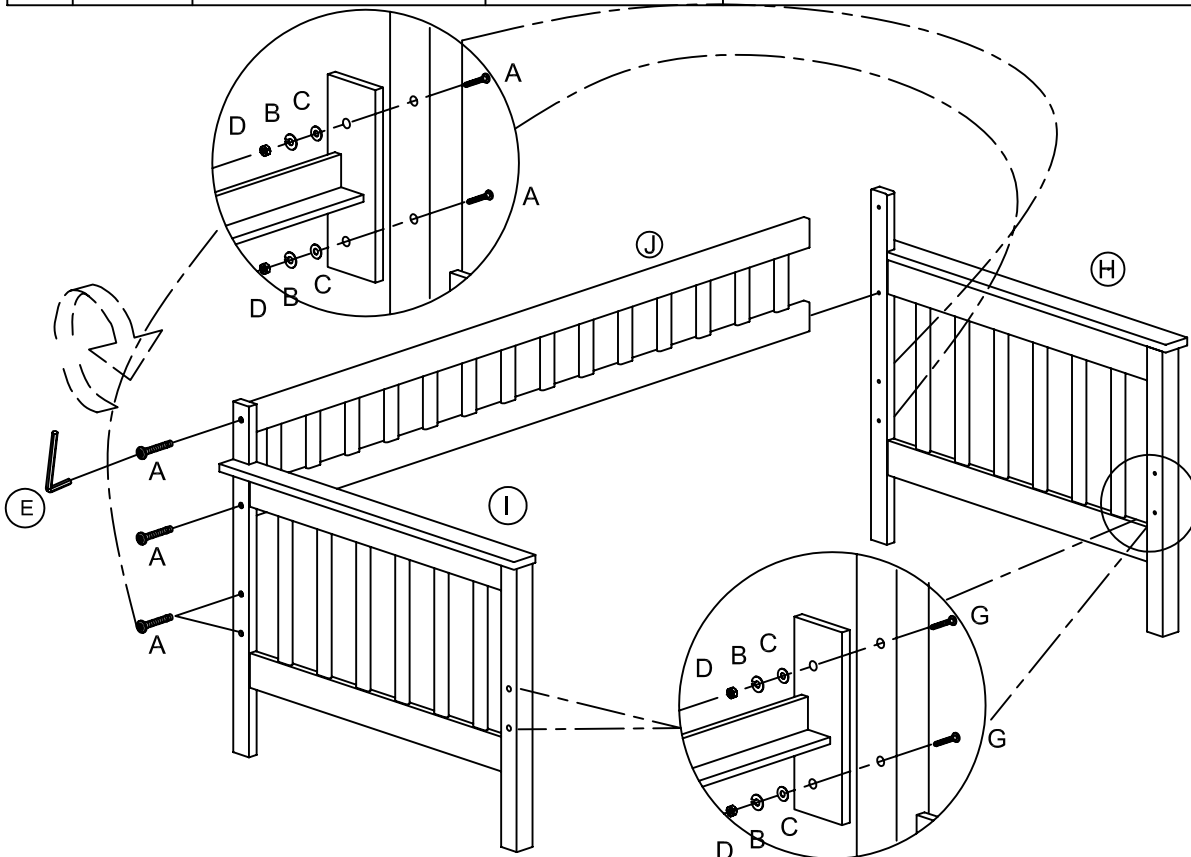

STEP 1

Begin assembly by attaching each Side Panel (H & I) To the Back Panel (J) using 2 Allen Bolts (A) per each side to hold in place. Tighten all bolts using the Allen Wrench (E) that has been provided.

STEP 2

Attach the Link Spring (*Not Included) to each Side Panel (H & I) using 2 Allen Bolts (A), 2 Flat Washers (C), 2 Spring Washers (B) & 2 Hex nuts (D) per each back post. And using 2 Allen Bolts (G), 2 Flat Washers (C), 2 Spring Washers (B) & 2 Hex nuts (D) per each front post of Side Panel. Tighten all bolts. The assembly is now complete.

CARE & MAINTENANCE: The touch of a soft cloth is all the maintenance the finish of your new Headboard will ever need.

Please do not use harsh or abrasive cleaners for polishing.

as they may cause damage to the finish. Periodic checks are recommended to make sure that all bolts, screws and nuts securely tightened.