

ASSEMBLY INSTRUCTION

FULL SLEIGH BED

ITEM: 325 - 325 FW

PAGE 1 OF 2

HARDWARE LIST

N.O	Qty	Description	Picture
A	12	Allen bolt Ø1/4" x L2"3/4	
B	12	Barrel Nuts	
C	16	Wood Dowels Ø10 x 40mm	
D	8	Screws Ø4 x 30mm	
E	1	Allen key M4	
F	8	Allen bolt Ø5/16" x L1"1/4	
G	2 set	Bolt Ø1/4" x L1"3/4	
H	2	Metal " U "	
I	28	Screws Ø4 x 20mm	
J	4	Metal Plate	
K			
L			
N			

PART LIST

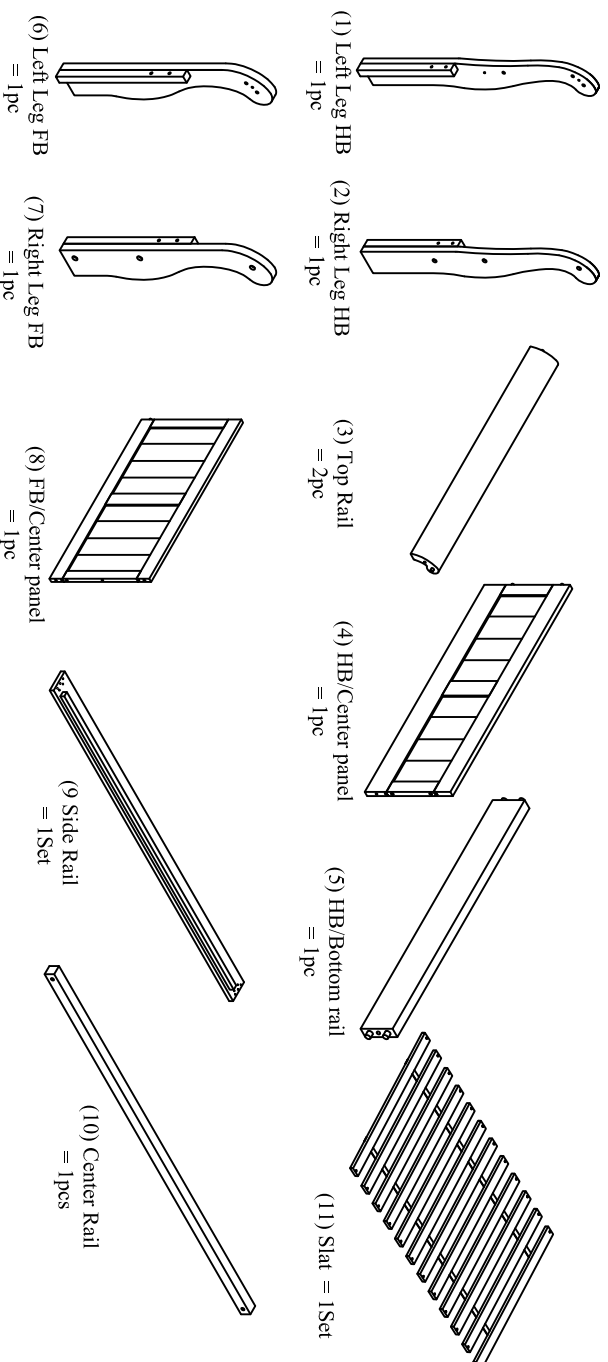

STEP 1

Assembly Top rail (3) with Center panel (4) before

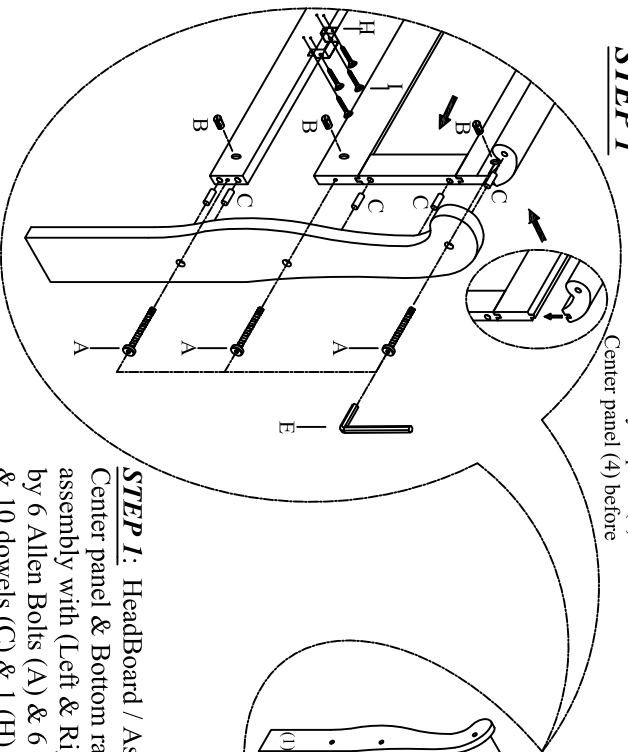

STEP 1: HeadBoard / Assembly

Center panel & Bottom rail assembly with (Left & Right) Leg (1 & 2) by 6 Allen Bolts (A) & 6 Barrel nuts (B) & 10 dowels (C) & 1 (H) & 4 screws (I).

STEP 2

Assembly Top rail (3) with Center panel (8) before

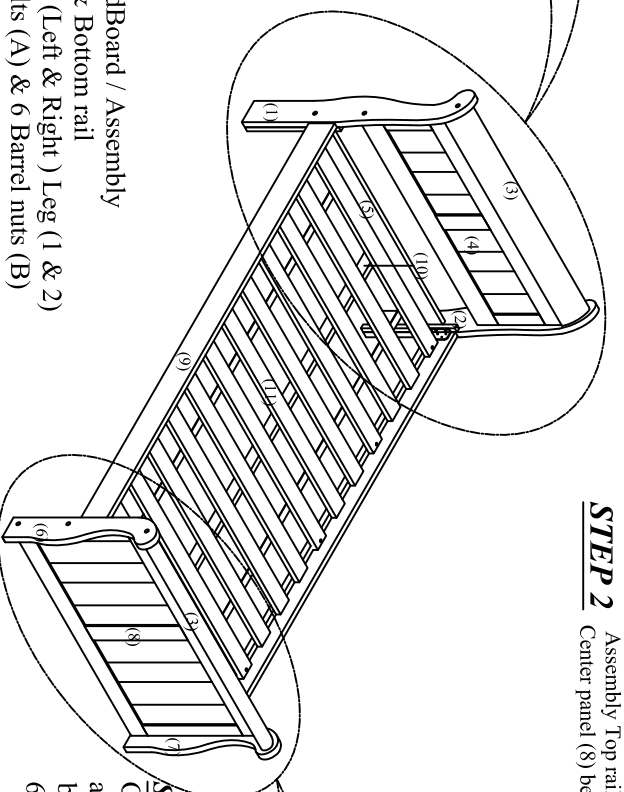

STEP 2: FootBoard / Assembly

Center panel & Bottom rail assembly with (Left & Right) Leg (6 & 7) by 6 Allen Bolts (A) & 6 Barrel nuts (B) & 6 dowels (C) & 1 (H) & 4 screws (I).

MADE IN VIET NAM

ASSEMBLY INSTRUCTION

FULL SLEIGH BED

ITEM: 325 - 325 FW

STEP 5

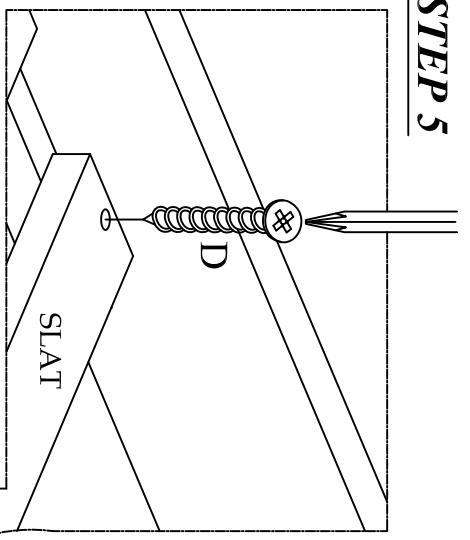

STEP 5
Slat (11) assembly with Side Rail
by 8 Screws (D).
The assembly is now complete.

STEP 4

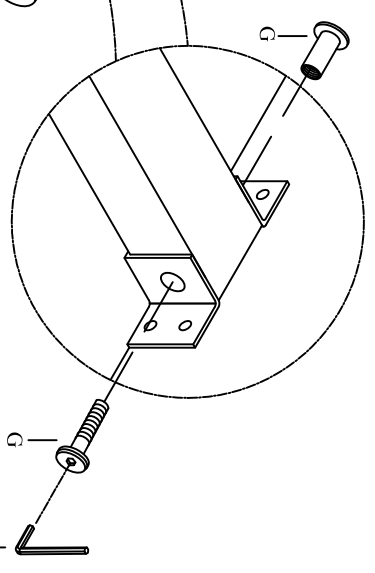

STEP 4
HB/FB assembly with Center Rail (10)
by 2 Bolts (G) .

STEP 3

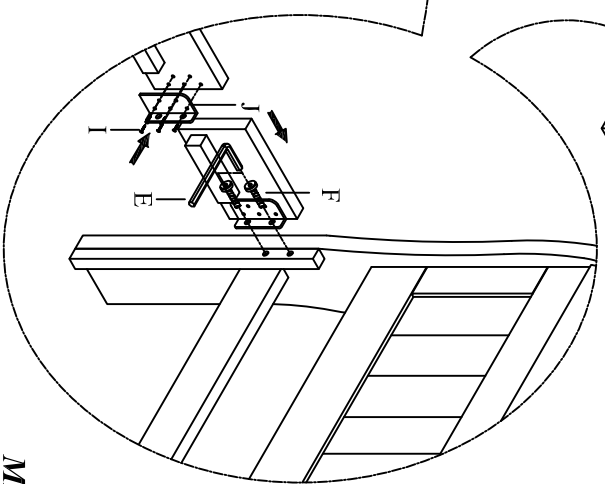

STEP 3
-Metal plate (J)assembly with side rail
by 20 screws (K)
-HB/FB assembly with Side Rail (9)
by 8 Allen Bolts (F)

