

**ASSEMBLY INSTRUCTION**  
**Model : 235 CG - BOOK CASE**

**BEFORE YOU BEGIN:**  
open, identify and count all hardware and parts. You should have everything on the **HARDWARE INCLUDED** and **PARTS INCLUDED** list provided with these instructions.

Assemble on a clean flat surface to assure that parts fit together squarely and flush. We recommend a carpeted surface.  
You may also wish to use a blanket to prevent scratching of wood during the assembly process.

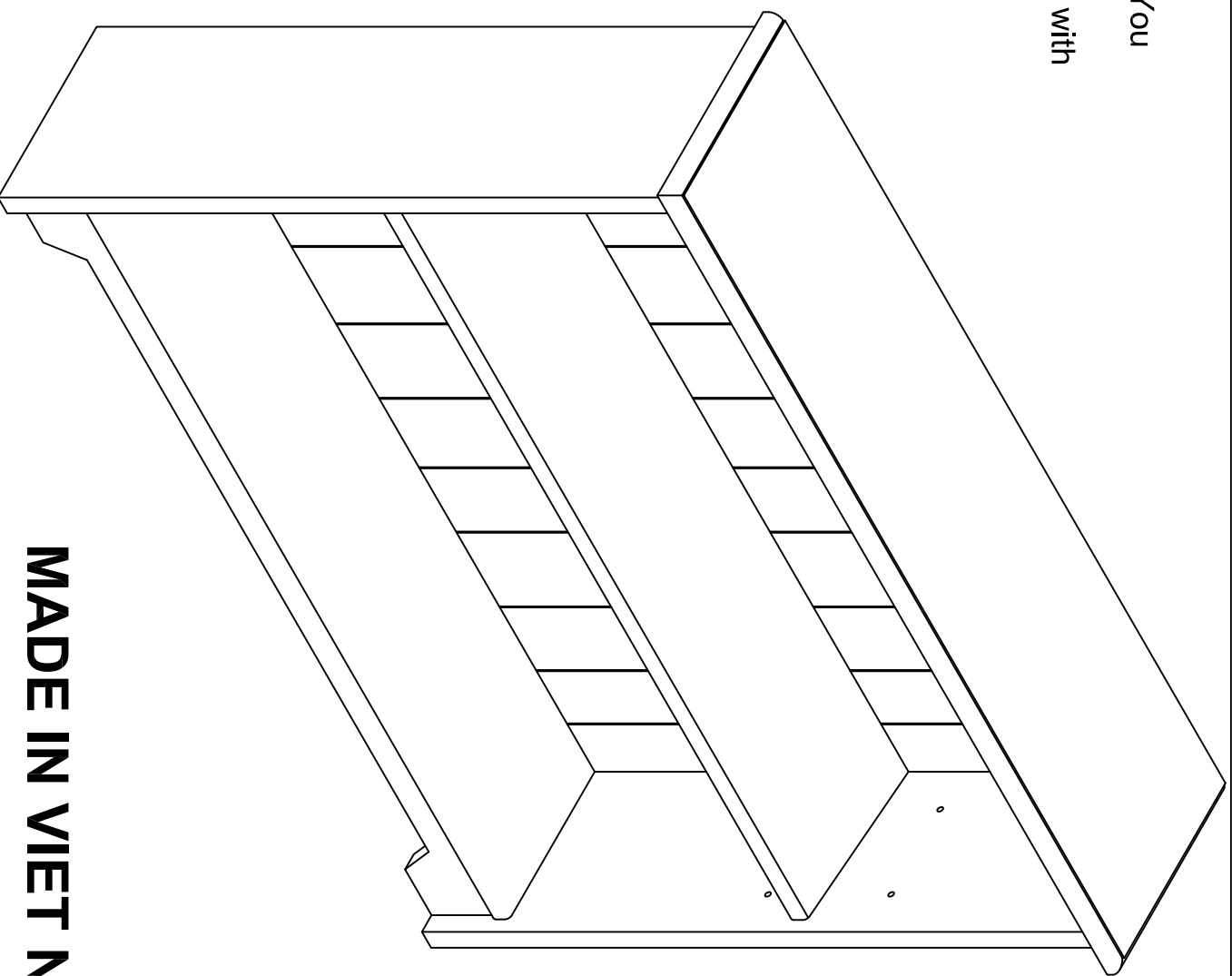

**MADE IN VIET NAM**

# ASSEMBLY INSTRUCTION

## Model : 235 CG - BOOK CASE

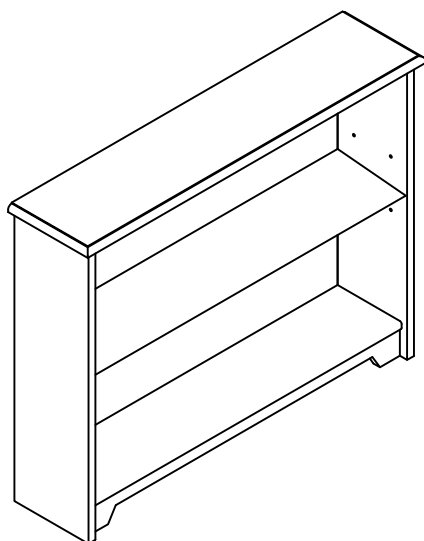

### HARDWARE LIST

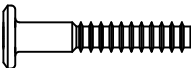
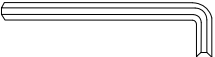
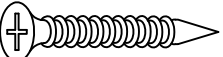
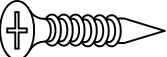
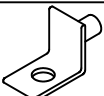
<b>A</b>		Ø8 * 30mm	14 pcs
<b>B</b>		Ø1/4 * 30mm	8 pcs
<b>C</b>		Ø4 * 50mm	1 pc
<b>D</b>		Ø4 * 30mm	2 pcs
<b>E</b>		Ø3.5 * 15mm	4pcs
<b>F</b>			4pcs

For easy identification during assembly sort hardware into separate piles making sure you have correct quantities of each.  
Using the incorrect hardware may lead to damage

## PARTS INCLUDED

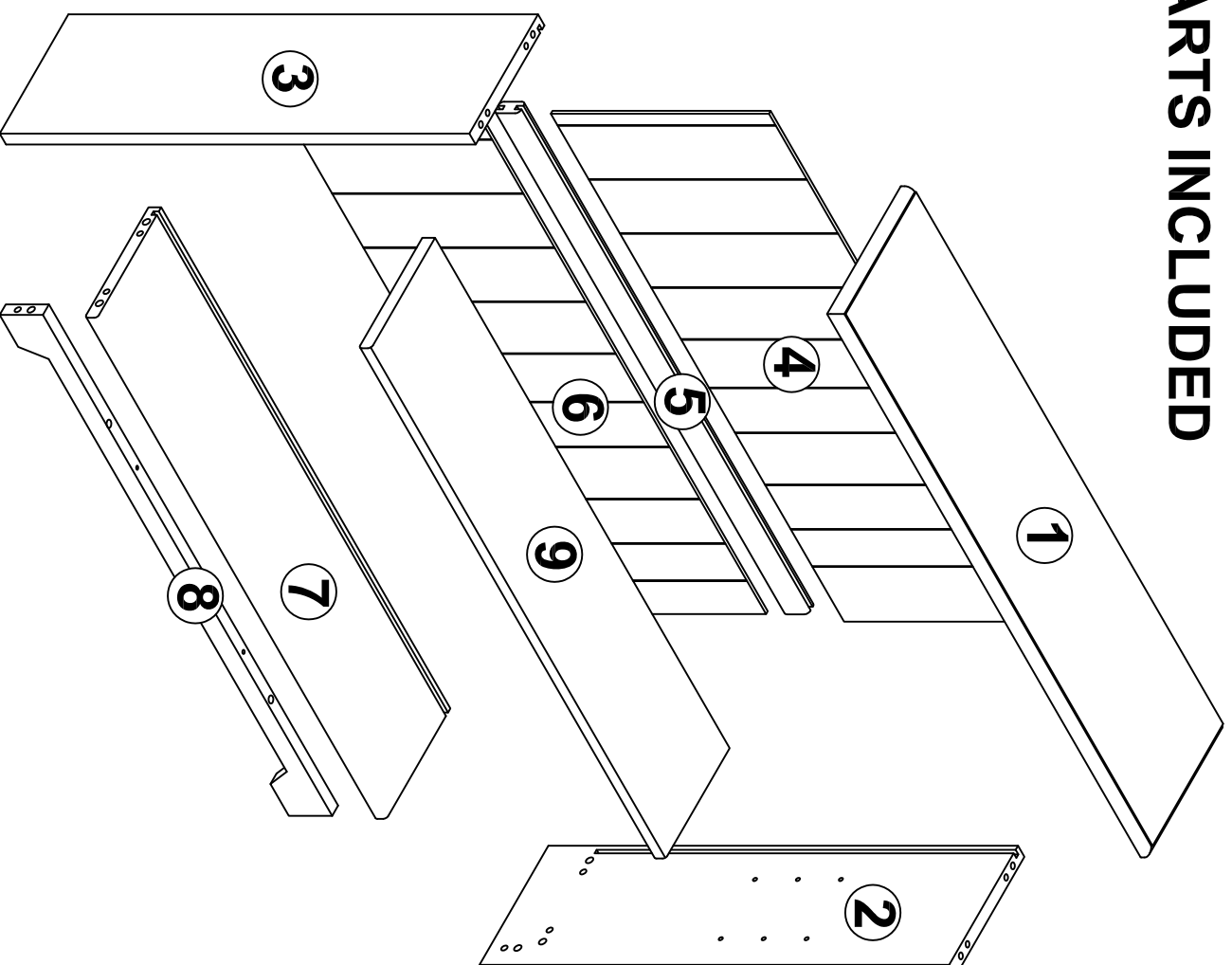



Locate and identify pieces required for assembly.

**CAUTION:** some pieces may look alike but may have some screw or dowel in different locations.  
Be sure to positively identify parts before fastening.

# ASSEMBLY INSTRUCTION

## Model : 235 CG - BOOK CASE

Step 1

<b>A</b>		Ø8 * 30mm	4 pcs
<b>B</b>		Ø1/4 * 30mm	4 pcs

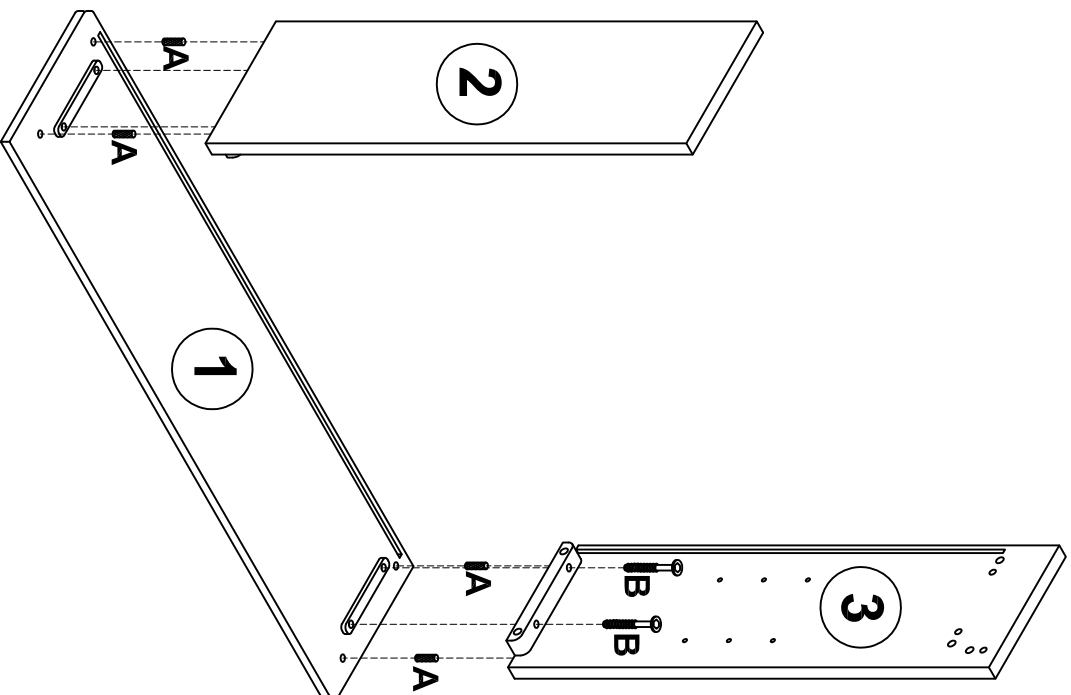

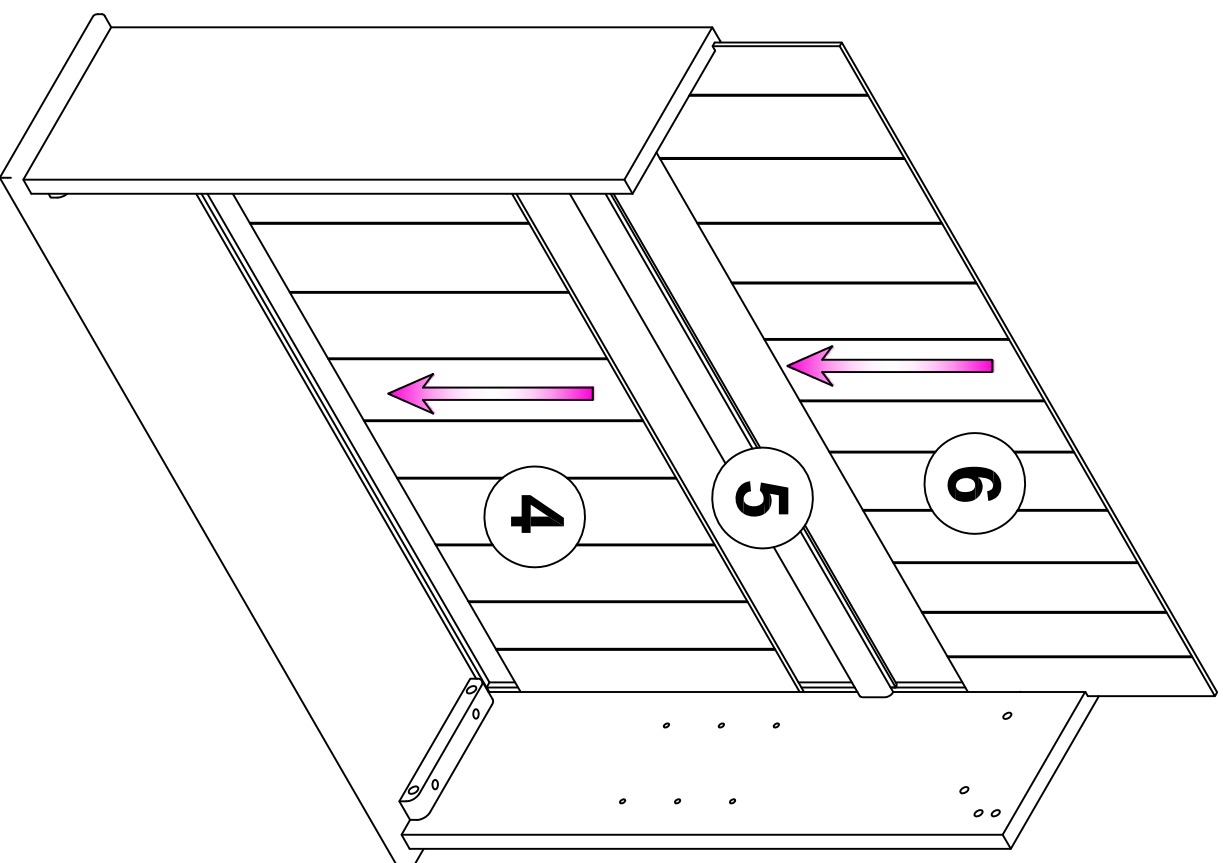

Step 2



# ASSEMBLY INSTRUCTION

## Model : 235 CG - BOOK CASE

Step 3

<b>A</b>		Ø8 * 30mm	10 pcs
<b>D</b>		Ø4 * 30mm	2 pcs

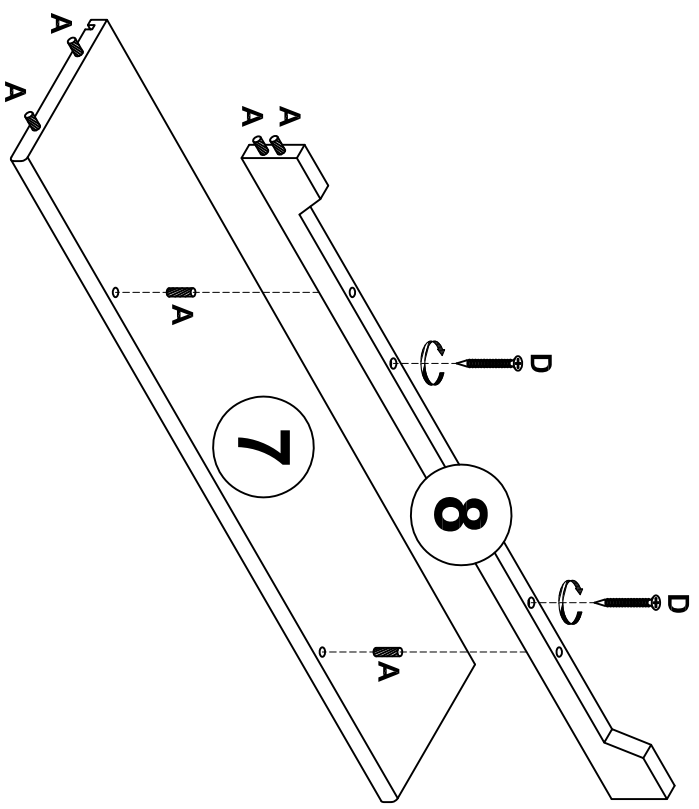

Step 4

<b>B</b>		Ø1/4 * 30mm	4 pcs
----------	---	-------------	-------

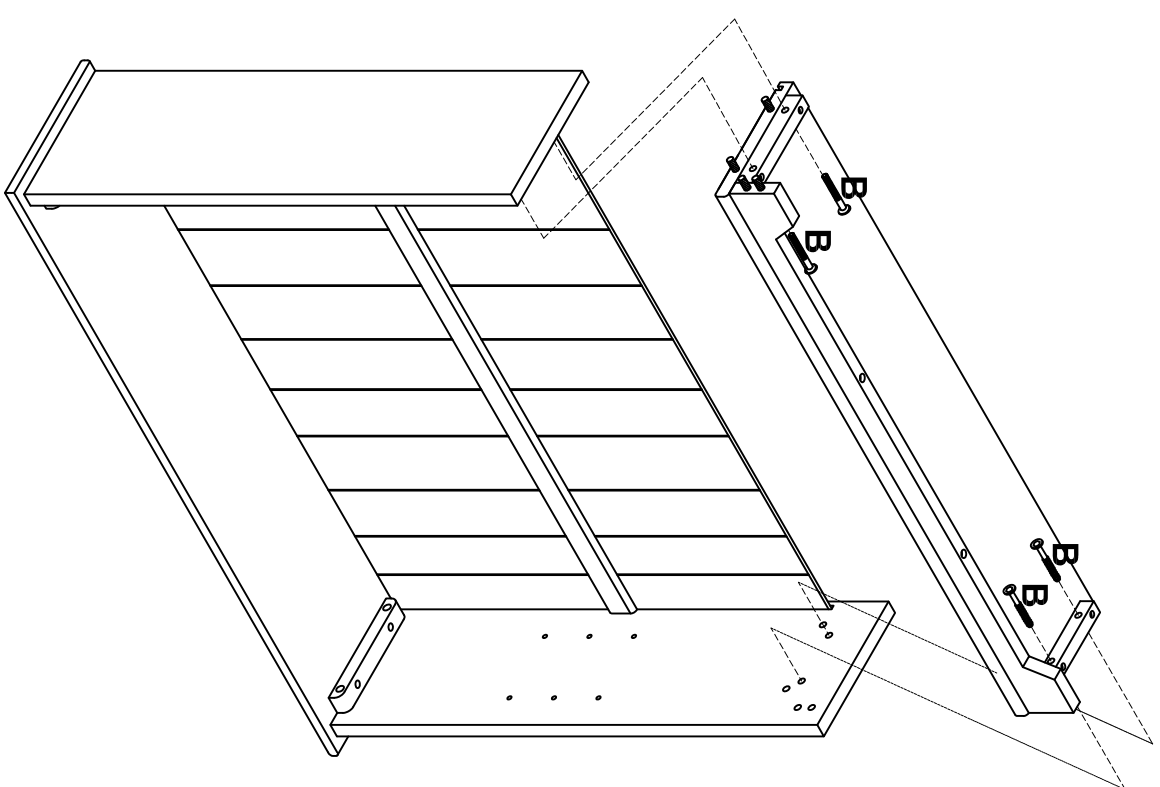

**ASSEMBLY INSTRUCTION**  
**Model : 235 CG - BOOK CASE**

**Step 5**

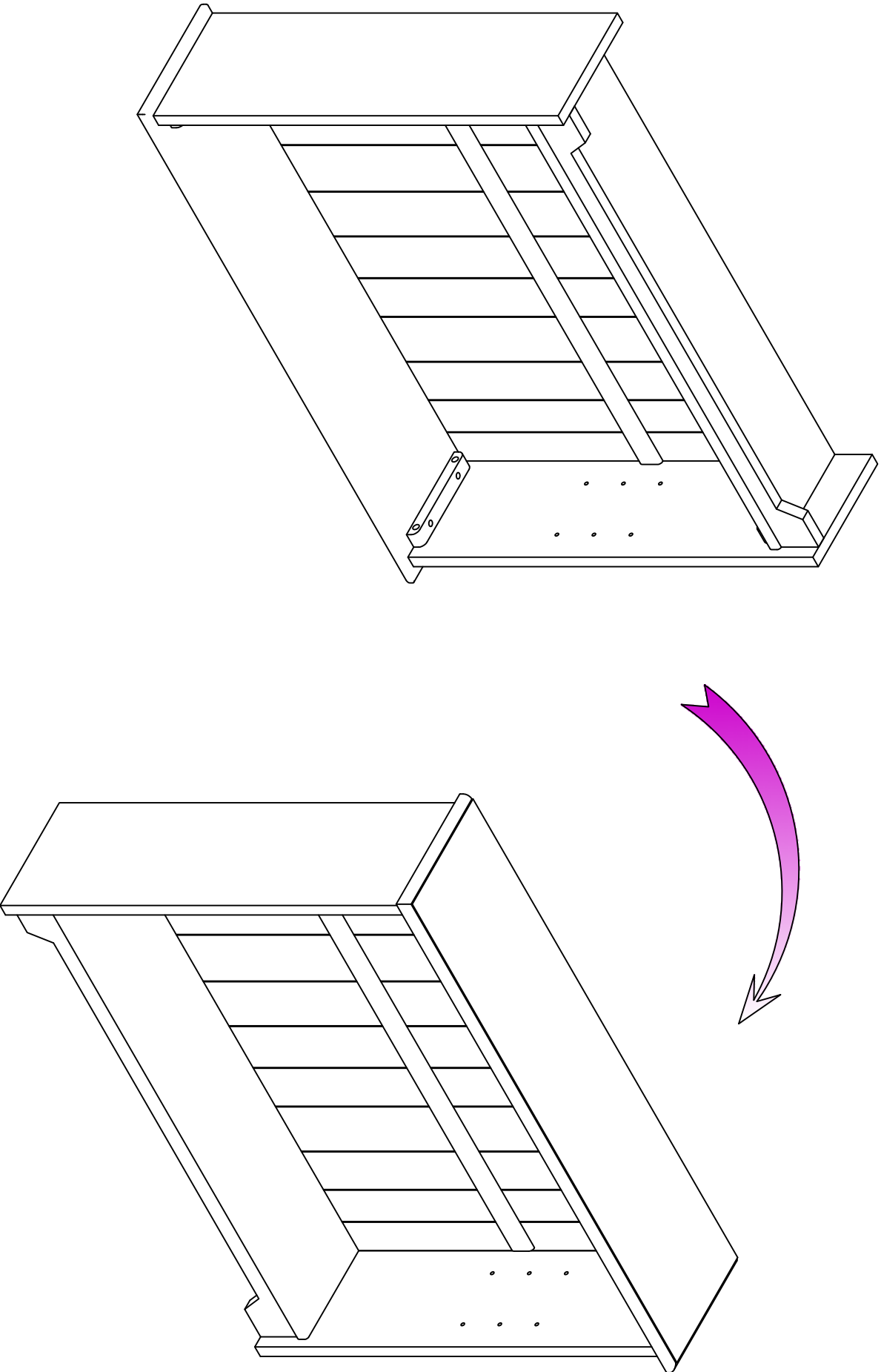

**ASSEMBLY INSTRUCTION**  
**Model : 235 CG - BOOK CASE**

Step 6

**F**



4pcs

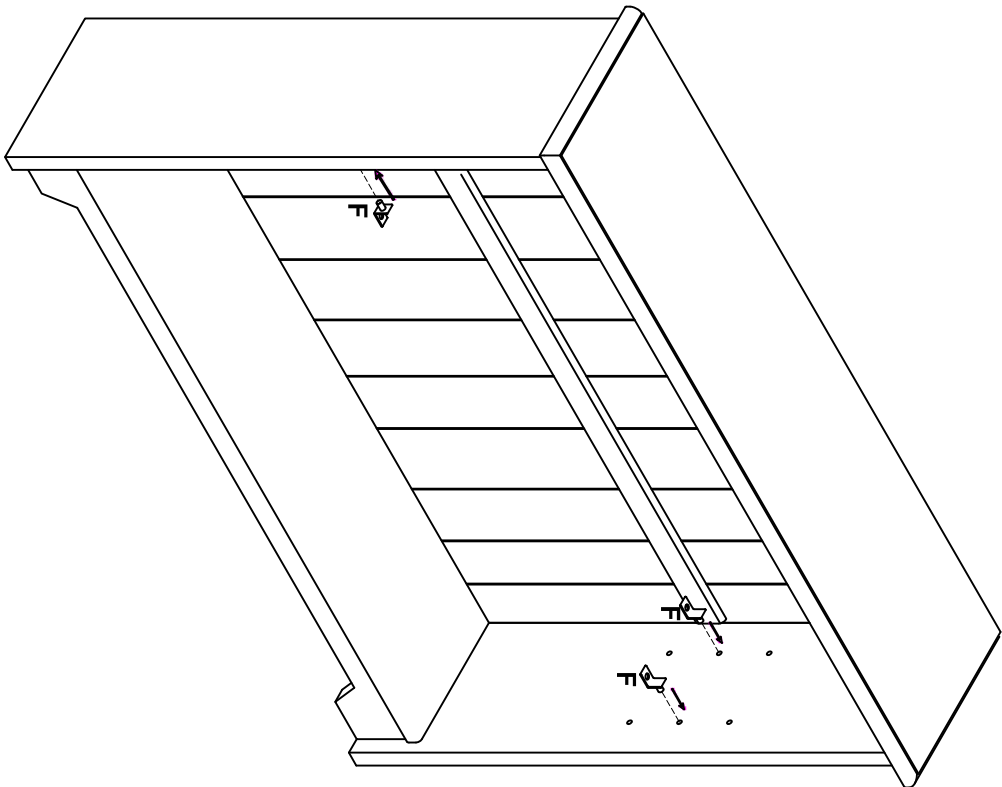

Step 7

**E**



Ø3.5 \* 15mm

4pcs

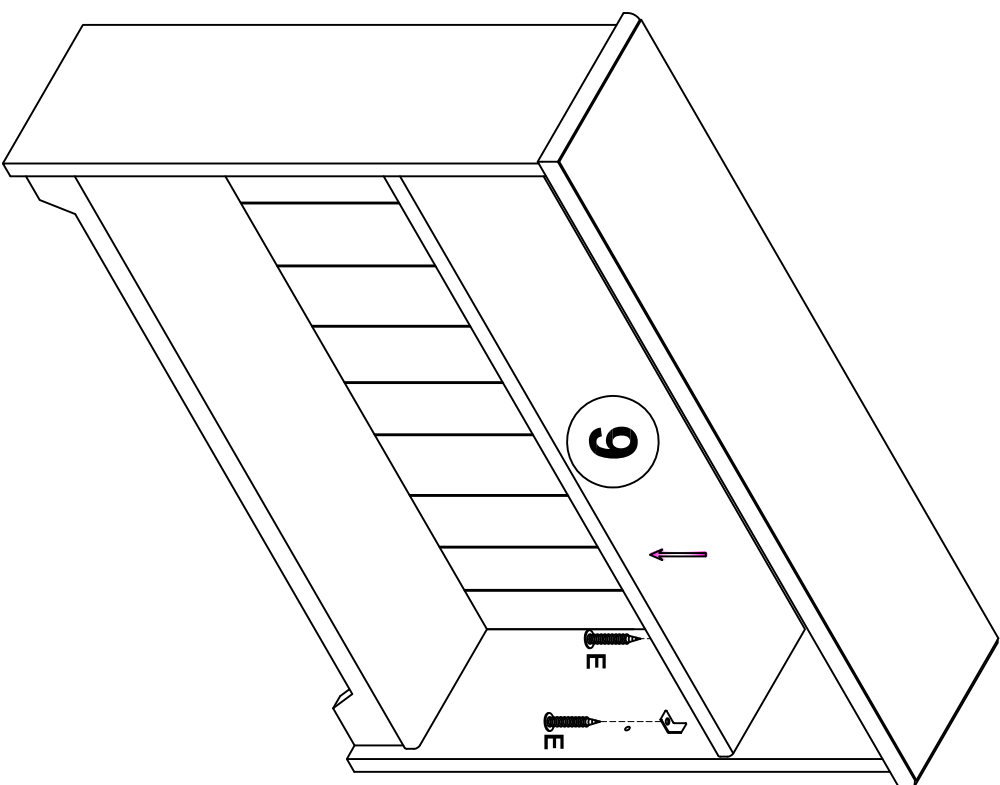

**ASSEMBLY INSTRUCTION**  
**Model : 235 CG - BOOK CASE**

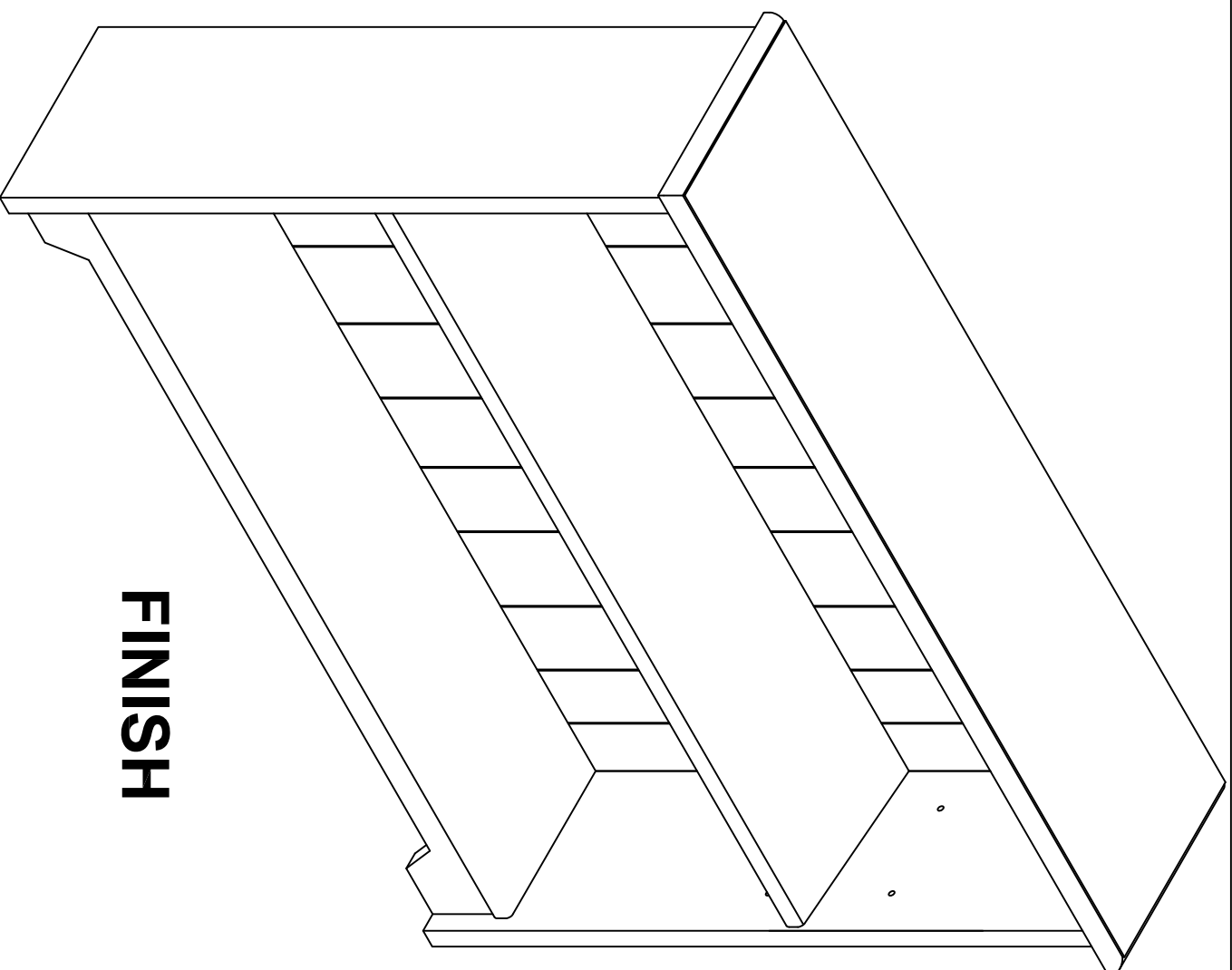

**FINISH**