

# ASSEMBLY INSTRUCTION

## FULL SLEIGH CAPTAIN BED

ITEM: 125 - 125 FW

PAGE 1 OF 2

### HARDWARE LIST

N.O	Qty	Description	Picture
A	12	Allen bolt Ø1/4" x L2"3/4	
B	12	Barrel Nuts	
C	16	Wood Dowels Ø10 x 40mm	
D	8	Screws Ø4 x 30mm	
E	1	Allen key M4	
F	8	Allen bolt Ø5/16" x L1"1/4	
G	2 set	Bolt Ø1/4" x L1"3/4	
H	2	Metal " U "	
I	28	Screws Ø4 x 20mm	
J	4	Metal Plate	
K			
L			
N			

### PART LIST

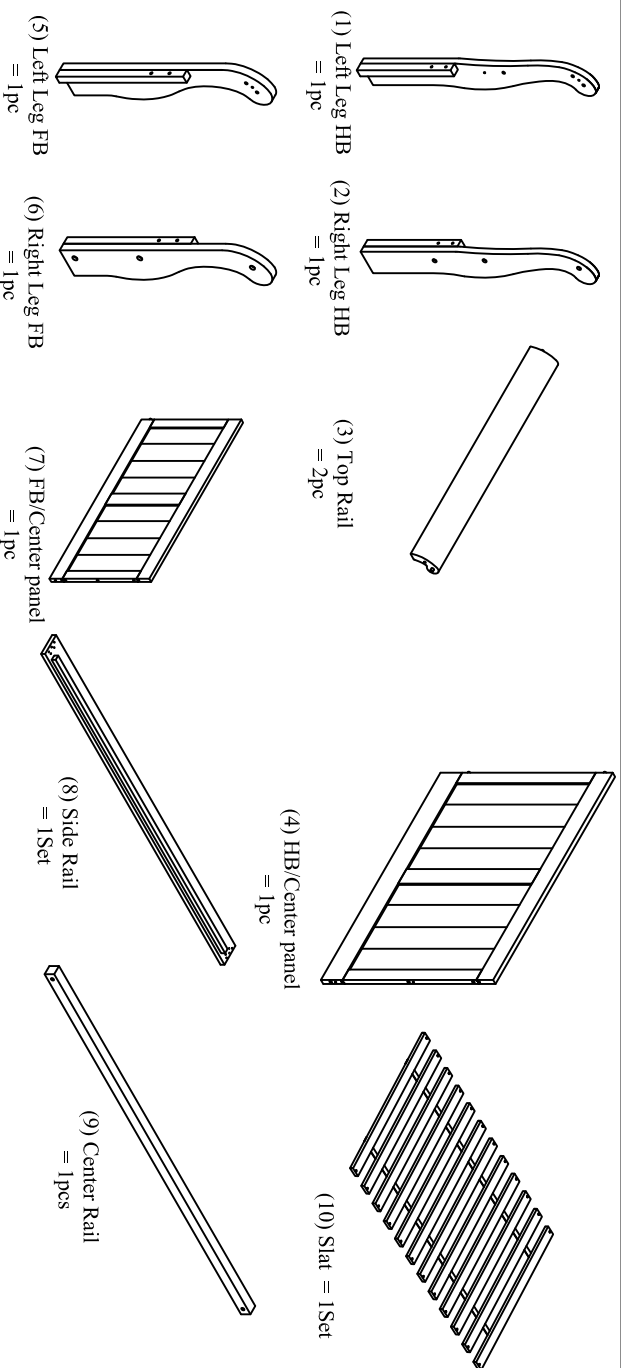

### STEP 1

Assembly Top rail (3) with Center panel (4) before

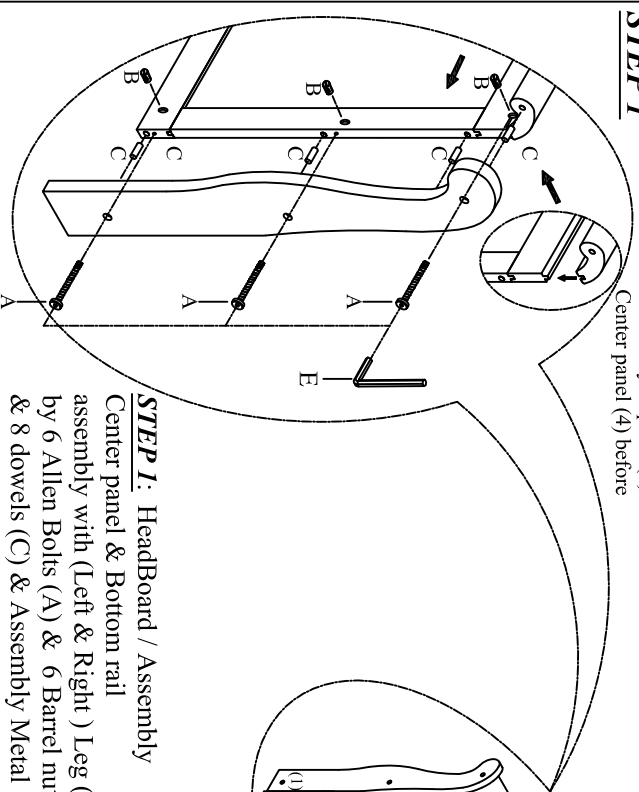

**STEP 1:** HeadBoard / Assembly Center panel & Bottom rail assembly with (Left & Right ) Leg (1 & 2) by 6 Allen Bolts (A) & 6 Barrel nut (B) & 8 dowels (C) & Assembly Metal " U " with 1 (H) & 4 screws (I).

### STEP 2

Assembly Top rail (3) with Center panel (8) before

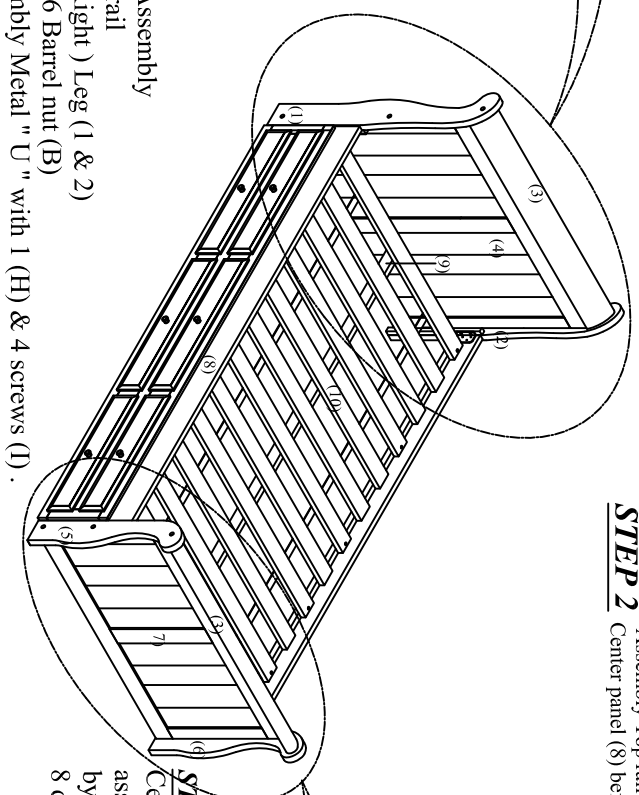

**STEP 2:** FootBoard / Assembly Center panel & Bottom rail assembly with (Left & Right ) Leg (5 & 6) by 6 Allen Bolts (A) & 6 Barrel nut (B) & 8 dowels (C) & Assembly Metal " U " with 1 (H) & 4 screws (I).

**MADE IN VIET NAM**

# ASSEMBLY INSTRUCTION

## FULL SLEIGH CAPTAIN BED

ITEM#: 125 - 125 FW

PAGE 2 OF 2

### STEP 5

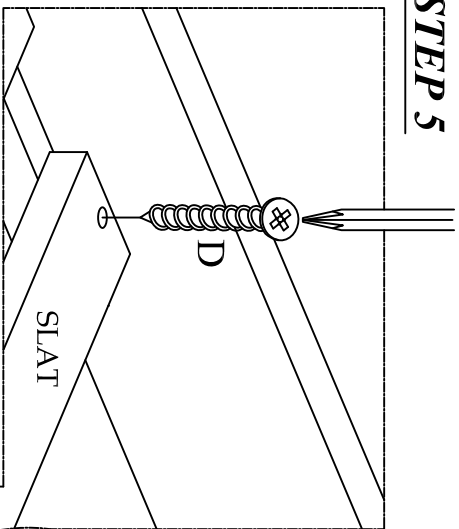

**STEP 5**  
Slat (11) assembly with Side Rail  
by 8 Screws (D).  
The assembly is now complete.

### STEP 4

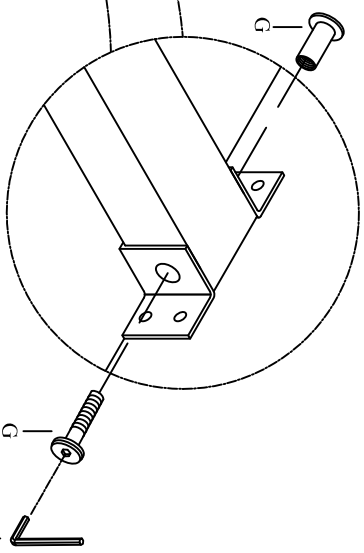

**STEP 4**  
HB/FB assembly with Center Rail (10)  
by 2 Bolts (J).

### STEP 3

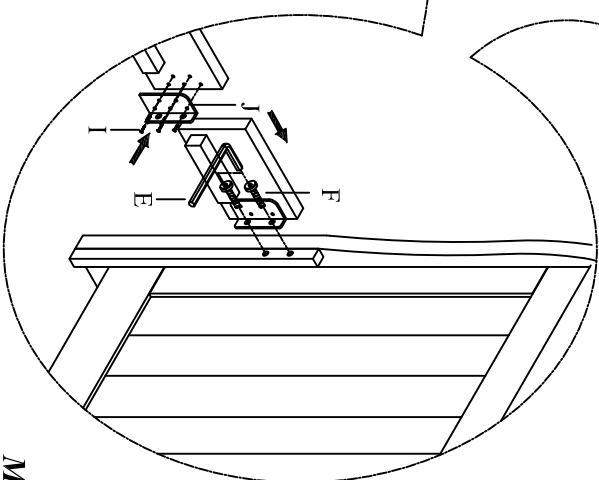

**STEP 3**  
-Metal plate (J)assembly with side rail  
by 20 screws (K)  
-HB/FB assembly with Side Rail (9)  
by 8 Allen Bolts (F)

